

General information about heat accumulating fireplaces

Heat accumulating fireplaces differ from other fireplaces in that they are intended to provide a moderate heat for prolonged periods with a limited time of firing. Conventional fireplaces give off strong heat during the firing period but with a very limited cool-down period.

The heat accumulating fireplaces from Nordpeis have a long duct system where the heat developed in the combustion chamber passes through the duct system before it exits through the chimney. The heat from the gases is absorbed by the material surrounding the smoke ducts, and by the time the smoke exits through the chimney, the temperature is reduced to little over 100 °C (212 °F). The efficiency of a well-constructed heat accumulating fireplace is thus far better than the efficiency of a conventional fireplace.

A heat accumulating fireplace can keep an even temperature throughout the day with only two heating cycles.

Bypass Damper

When the bypass damper is open the smoke gasses exit directly through the chimney without first travelling through the duct system. This gives far better draught which can be beneficial for lighting a fire when the fireplace and/or the chimney are cold. The bypass damper should only be open when needed, for short periods (10-15 minutes), when lighting a fire, and possibly when inserting new firewood in order to prevent the release of smoke or ash. Prolonged heating with open bypass damper can lead to exceeding the maximum allowable chimney temperature.

Flue Damper

The flue damper seals off the fireplace from the chimney. This is to ensure that as much as possible of the stored heat in the fireplace is emitted to the room and not out of the chimney after the last load in the heating cycle. The damper has a small built-in opening, so even when closed it protects against smoke being produced and released. The flue damper must be open during firing, but can be closed after the last load of firewood has become ember.

Air Vent

When firing in a heat accumulating fireplaces the air vent is traditionally kept open to a maximum. This ensures optimal combustion and minimises carbon deposits in the smoke duct system. In addition it makes it easier to keep the glass clean during intensive firing. However, should one wish for a longer burn period and slower flames, the air vent is adjusted and reduced. Salzburg is equipped with secondary combustion technology, which can normally only be found on modern fireplaces. This ensures clean combustion and high efficiency, even at lower loads.

Cleaning the Smoke Duct System

When the fireplace is used every day throughout the heating season, we recommend that the smoke duct system is swept once yearly. This is to maintain the draught and efficiency. Soot isolate the ducts and thus lower the efficiency. One can also notice that the draught is reduced and that the flames are difficult to control with the air vent function. Remember that the fireplace must always be cold before it is swept / inspected.

Ash and Ash-pan

The ash-pan consists of an inner part which is used for the regular emptying of ashes. The duct system can be reached when the outer part of the ash-pan also is removed.

For the simplest possible way to sweep the ducts one should use a spring that is as flexible as possible (steel, Ø4-5mm, about 200 cm long) with associated brush (Ø50 - 80mm). This is then led down through the opening where the ash-pan was up into the duct system on each side. The entire depth of the duct should be swept. Soot that falls down and ends up in the bottom under the ash-tray can be removed with an ash vacuum cleaner.

By rear or lateral connection the flue can be swept by removing the smoke baffle and then opening the bypass damper.

The ashes must be emptied periodically. Please note that the ash may contain hot embers even several days after the fire has ceased. Use a container of non-combustible material to remove the ashes.

Weight

The home owner must ensure that the floor can withstand the load in relation to the total weight of the product.

Firewall

Freestanding fireplaces can be installed without a firewall. Observe all safety distances to combustible materials.

Connection to Chimney

Follow specifications from the chimney manufacturer for connection to the chimney. Dry stack the fireplace for accurate height and positioning of the flue/chimney connection.

The product is not compatible with top connected concrete chimney.

Maximum weight of steel chimney (top connection) is 300kg.

By top connection to steel chimney, we refer to the respective manufacturer's installation instructions.

Requirements for Floor Plate by Combustible Floor

Follow the requirements for floor plate (stone, steel, etc.) that apply in the country that the product is installed in.

Glue

The outer elements should be glued with the acrylic which is included. Make sure that all the surfaces that are to be glued are free of dust. The surfaces can be cleaned for better adhesion. Ensure that the surfaces are dry before spreading on the acrylic. Once the fireplace is assembled, fill the joints with acrylic and even it out with a sponge or finger and some soapy water, in order to have a clear indentation between the elements (FIG Z).

Minor Damages

Transportation and handling can cause minor damages to the product. This can be repaired with the powder glue which is included. For a perfect result you can fill and grind with a suitable filler on top of the powder glue. Fill smaller cracks and uneven surfaces with a float or a brush. If the damage is deep, it is recommended to fill in several stages to avoid sinking. Even out with e.g. a damp sponge or a float.

Painting

The surface of the chimney surround is developed to be painted without priming work. Use latex or acrylic based paint (emulsion paint), or cement-based textured paint. In the unlikely case that there are some irregularities in the surface, these can be filled with the acrylic which is included, or a light and appropriate filling material. Any surface that has been filled needs to be smoothed with fine sand paper.

Polishing

If a more traditional and polished surface is wished for, it is recommended to dampen the surround and then cover it with tile adhesive (powder glue) and a fibreglass mesh, prior to possibly adding mortar or mineral polish.

Tiles

This fireplace can also be partially or completely covered with tiles / natural stone of your choice. As for the section above on "Polishing", we recommend that the chimney surround is dampened before it is covered with tile adhesive (powder glue) and a fibreglass mesh. This is to ensure good adhesion and prevent the formation of cracks at the joints of the surround.

Please note that the adhesive and mortar must set before firing in the fireplace. Follow the instructions from the mortar/adhesive producers.

Regardless of surface treatment it is a great advantage to mask the entire door frame to avoid having to clean it later.

Please note that the air gap between the surround and the door frame must not be filled with glue, mortar or similar.

Thermotte®

The insulating plates in the burn chamber contribute to a high combustion temperature, which leads to cleaner combustion of the wood and a higher rate of efficiency. Any fissures in the plates will not reduce their insulation efficiency. If new plates are needed, contact your dealer.

Please note: Wood logs that are too long can cause additional strain and crack the plates, due to the tension created between the side plates. Also note that the Thermotte® plates may release coloured dust when touched.

Cracks in the i PowerStone

Due to thermal effects there may be small cracks / fissures in the PowerStone. This is natural and does not affect the product's function or safety.

Warranty

Nordpeis Salzburg M benefits of a 5 years warranty. The warranty requires the product to be installed in accordance with applicable laws and regulations, as well as the user manual. Notification of damage and possible consignment of parts for replacement must be done immediately to the retailer where the stove was bought. Any claim must be submitted with a dated purchase invoice or a valid warranty card and serial number.

The warranty does not include consumables such as: Thermotte®, smoke baffle, glass and gaskets. Should any of the mentioned parts break, or need to be changed due to wear and tear, new parts can be ordered from your retailer. However, if a material or production error can be documented on any of the mentioned parts, the warranty is valid for 2 years after the date of purchase.

The warranty does not include damages that are caused by wrong installation or misuse of the stove, e.g. incorrect draught regulation or use of incorrect combustion material. The warranty does neither include interference with operations outside the control of Nordpeis, such as chimney draught etc. There is no compensation for third party damage or damage to other items caused by use of the product.

Door and Glass

Should there be any soot on the glass it may be necessary to clean it. Use dedicated glass cleaner, as other detergents may damage the glass. (NB! Be careful, even dedicated glass cleaner can damage the varnish on the door frame). A good advice for cleaning the glass is to use a damp cloth or kitchen roll paper and apply some ash from the burn chamber. Rub around the ash on the glass and finish off with a piece of clean and damp kitchen roll paper. NB! Only clean

when the glass is cold.

Check regularly that the transition between the glass and the door is completely tight. Possibly tighten the screws that hold the glass in place - but not too hard, as this can cause the glass to crack.

Periodically, it may be necessary to change the gaskets on the door to ensure that the burn chamber is air tight and working optimally. These gaskets can be bought as a set, usually including ceramic glue.



Recycling of the refractory glass

Refractory glass cannot be recycled. Old glass, breakage or otherwise unusable refractory glass, must be discarded as residual waste. Refractory glass has a higher melting temperature, and can therefore not be recycled together with glass. In case it would be mixed with ordinary glass, it would damage the raw material and could, in worst case end the recycling of glass. It is an important contribution to the environment to ensure that refractory glass does not end up with the recycling of ordinary glass.

Packaging Recycle

The packaging accompanying the product should be recycled according to national regulations.

Firing Rhythm

A heat storing product should not be fired in too aggressively as this may damage the product. In order to get the most out of a heat storing product, it is therefore important to optimise the firing rhythm and the size of the loads. Read the combustion rates and load sizes that apply to your product.

Advice on Lighting a Fire

The best way to light a fire is with the use of lightening briquettes and dry kindling wood. Newspapers cause a lot of ashes and the ink is damaging for the environment. Advertising flyers, magazines, milk cartons and similar are not suitable for lighting a fire. Good air supply is important at ignition. When the flue is hot the draught increases and door can be closed.

Warning: NEVER use a lighting fuel such as petrol, paraffin, methylated spirits or similar for lighting a fire. This could cause injury to you as well as damaging the product.

Use clean and dry wood with a maximum moisture content of 20% and minimum 16%. The wood logs should dry for a minimum of 6 months after it is cut. Humid wood requires a lot of air for the combustion, as extra energy/heat is required for drying the humid wood and heat effect is therefore minimal. In addition this creates soot in the chimney with the risk of creosote and chimney fire.

Storing of Wood

In order to ensure that the wood is dry, the tree should be cut in winter and then stored during the summer, under roof and in a location with adequate ventilation. The wood pile must never be covered by a tarpaulin which is lying against the ground as the tarpaulin will then act as a sealed lid that will prevent the wood from drying. Always keep a small amount of wood indoors for a few days before use so that moisture in the surface of the wood can evaporate.

Firing

Not enough air to the combustion may cause the glass to soot. Hence, supply the fire with air just after the wood is added, so that the flames and gases in the combustion chamber are properly burnt off. Open the air vent and have the door slightly ajar in order for the flames to establish properly on the wood.

Note that the air supply for the combustion also can be too large and cause an uncontrollable fire that very quickly heat up the whole hearth to an extremely high temperature (when firing with a closed or nearly closed door). For this reason you should never fill the combustion chamber completely with wood.

In order to obtain an optimal combustion, the temperature needs to reach 600-800°C. It is recommended to keep an even fire with a small amount of wood. If too many logs are put on the hot ember, the air supply will not be sufficient for reaching the require temperature, and the gases will be released unburnt. For this reason it is important to increase the air supply just after adding the logs in order to have proper flames in the burn chamber so that the gases are burnt.

Choice of Fuel

All types of wood, such as birch, beech, oak, elm, ash and fruit trees, can be used as fuel in the stove. Wood species have different degrees of hardness - the higher the hardness of the wood, the higher the energy value. Beech, oak and birch havest the highest degree of hardness.

NB! We do not recommend the use of fuel briquettes / compact wood in our combustion chambers, as these products may develop significantly higher temperature than the combustion chamber can withstand. Burning briquettes / compact wood is at your own risk and can cause invalidity of the warranty.

Warning:

NEVER use impregnated wood, painted wood, plywood, chipboard, rubbish, milk cartons, printed material or similar. If any of these items are used as fuel the warranty is invalid.

Common to these materials is that they during combustion can form hydrochloric acid and heavy metals that are harmful to the environment, you and the stove. Hydrochloric acid can also corrode the steel in the chimney or masonry in a masonry chimney. Also, avoid firing with bark, sawdust or other extremely fine wood, apart from when lighting a fire. This form of fuel can easily cause a flashover that can lead to temperatures that are too high.

Warning: Make sure the stove is not overheated - it can cause irreparable damage to the product. Such damage is not covered by the warranty.

Source: "Håndbok, effektiv og miljøvennlig vedfyring" by Edvard Karlsvik SINTEF Energy Research AS and Heikki Oravainen, VTT.
<http://www.eufirewood.info>

For your own safety, comply with the assembly instructions. All safety distances are minimum distances. Installation of the fireplace must comply with the current rules and regulations of the country where the product is installed. Nordpeis AS is not responsible for wrongly assembled fireplaces.

*Subject to errors and changes.
For the latest updated version go to www.nordpeis.c*

Salzburg M

Surface temperature °C	90-130
Length of wood logs	300 mm
Weight Low	ca. 610 kg
Weight High	ca. 717 kg
Load size (kg)	2 kg
Max nr. loads	5
Loading interval	1 / hour
Nr. firing cycles per 24 hours	1

Attention!

It is recommended to use a qualified professional when installing a new fireplace.

Distance illustration (FIG 1)

*The illustration indicates the approximate centre height of the recess for the flue. Consider possible inclination of the flue prior to making perforating the chimney. Distortions in floors and walls may also influence the height, dry stack therefore the fireplace for accurate height and positioning of the flue/chimney connection. If a fresh air supply set (accessory) is connected through the floor, mark where the hole should be.

Attention! Since the inner core is composed of many layers the connection height may vary by up to a few centimeters from installation to installation

Safety distances (FIG 2)

Ensure that the safety distances are complied with.

Firing Rhythm and Drying Procedure

The fireplace contains a lot of moisture that must be released before it can be exposed to the recommended firing rhythm as described below. In order to dry out the fireplace, we recommend that it is heated up with a small fire consisting of 0.5 to 1 kg kindling wood with the flue damper and air vent left open. The bypass damper is closed once the fire is well lit so that the hot smoke circulates through all the ducts. Let the fire burn out and maintain the air valve and flue damper open.

This procedure is repeated twice, not sooner than 24 hours after the first time. Should this drying procedure not be followed there is a risk that the elements crack.

A heat-accumulating fireplace is designed to absorb thermal energy during a relatively short period of relatively intensive firing, and then release the accumulated heat over a longer period of time. The fireplace is designed to reach a surface temperature of between 90 and 130 °C during normal use. Heating beyond the recommended pattern will result in a higher surface temperature, which can cause discolouration of the paint, as well as higher temperatures against

combustible walls than calculated.

When the last load has passed into the ember phase with few embers left, the air vent and flue damper are closed to prevent heat escaping through the chimney. The bypass damper is opened in order give the airflow the shortest route to the chimney.

Remember to open the flue damper before using the fireplace again. The bypass damper is normally only necessary to open when lighting a fire when both the chimney and fireplace are cold, but it should in any case be closed within 10-15 minutes, as soon as the draught has picked up.

Due to the length of the smoke gas ducts, the fireplace is heated up somewhat unevenly. After lighting a fire, the front above the door and one of the sides will heat up first. The heat will then be evened out after a few hours of firing and when all the ducts have been warmed up.

Assembly (FIG 3 - FIG 60)

FIG 3

The ventilated base plate (1) is placed on the floor. It is important that the entire intended contact surface (FIG 3A) is in actual contact with the floor. This can be ensured by spreading a layer of tile adhesive or thin mortar on the floor before the base plate is placed against the floor. This is to ensure that the heavy fireplace is not left sitting on any irregularities and to ensure an even weight distribution of the fireplace. It is also important to ensure that this plate is level in both directions before proceeding with the installation.

Attention! The use of shims to level the base plate is not recommended as the differences in tension on the base plate can cause it to crack under the weight of the product.

If a fresh air supply (not included) is connected through the bottom plate, it is important to make a hole at the location of the recess which is placed under the base plate, before it is placed on any added adhesive or mortar, and to adapt air inlet flue before continuing with the installation.

Attention! If an air supply set is to be connected to the fireplace through the base plate, then the hole in the back surround (FIG 9) must be sealed off on the inside with the supplied plug before the element is lowered over the inner core.

FIG 4-7:

Place the first PowerStone bottomplate (2) in the centre of the base plate before the PowerStone element 3 is placed on top. Glue in place the transit element (5) for the fresh air supply connection with the acrylic which is included. If the fresh air supply is connected through the bottom plate, the hole is sealed off with supplied concrete lid (4).

If a fresh air supply set is not used, or if it is connected at the rear, the concrete lid should be placed in the recess in the bottom plate as shown in **FIG 7**. Whether the fresh air supply is connected from below or rear it is important that the connection between the flue and the concrete is properly sealed off with the acrylic that is included. This is to prevent leakage of cold air into the home.

FIG 8-11

Assemble the inner core and the surround. The inner core elements are equipped with gaskets on the contact surface that is to face upwards. There is therefore no need for further adhesives or sealing between each element. Ensure that the surfaces are clean and even, and that there are no pieces of concrete and so forth that may compromise the density between the elements.

The contact surfaces between the surround elements are to be glued with the acrylic that is included. If acrylic seeps out between the joints on the outside, remove it before it dries with a wet sponge / finger.

Attention! Ensure that the inner core is mounted in vertical, and that components are not displaced in relation to each other. There should be a 6-10 mm air gap between the inner core and the surround.

FIG 12

The 10 mm gasket that is to seal off the doorframe from the inner core is glued into the slot in the inner core with the acrylic that is included.

If the gasket between the core and the door is not sealing sufficiently above the door, use the enclosed 20x10 mm gasket for sealing

FIG 13

To ensure that the glass in the door is not damaged during installation, remove the transportation lock and lift the door up and out of the lower edge.

FIG14

Install the air ducts (a-b) on the doorframe. Unfasten the air-diffuser (c). Install the upper and lower clamps (d-e). Do not tighten the upper clamps, these should be turned into place behind the next layer of PowerStone and then tightened (FIG 16). When the doorframe is placed on the hearth, the air ducts will fit the gouge as shown in FIG 14b. The gasket joint should overlap the doorframe FIG 15. The doorframe must rest on the gasket under doorframe.

FIG 16-17

Mount the next Powerstone element. Now the doorframe can be attached with the fasteners as shown in **FIG 16**. Do not use more force than that the doorframe is held loosely in place against the gasket, as excessive force can displace the inner core. Light tensioning can be done when the fireplace is fully assembled, the weight of the elements will then prevent displacement. Ensure that the doorframe is mounted right at the centre in relation to the lateral elements.

The distance between the surround and doorframe should be equal at both the top and the bottom. This distance can be adjusted on the doorframe system as shown in **FIG 27**. **The door must be removed in order to do this, as shown in FIG 13**. This can also be fine-tuned after the entire fireplace has been mounted.

FIG 18-20

If the fireplace is supplied with additional top extension, this assembly is described in FIG 18-20. If this extension is not included, you can ignore these steps.

The Thermotte plates, as shown in FIG 22 and 48, must be exchanged for longer versions when assembling Salzburg M – High.

FIG 21-24

Assemble the remainder of the inner core and surround elements.

FIG 25-26

You can now choose whether to place the bypass damper arm on the right or the left side. The drilling in the inner core and the surround element, as well as the adjustment of the length of the arm must then be adapted to this option as shown in FIG 25.

If the fireplace is mounted next to a chimney or a wall, this must not prevent the opening of the bypass damper (the damper arm is pulled out). The bypass damper arm should be placed loosely in the gouge of the baffle plate as shown in FIG 26.

Attention! The gasket between the core elements will flatten slightly after assembly.

To prevent the damper arms from wedging, it is necessary to cut / drill out about 10 mm below the hole that is made for the damper arm. This applies to both damper arms

Attention! Wait to place the decoration ring on both damper arms until the product has been painted and used once.

Top Connection

FIG. 28-34:

Follow the steps for the top connection. The hole for the flue damper arm must be marked when the damper is placed as shown in FIG 31. The damper arm can be installed on either the right or the left side as shown in FIG 32. Pass the damper arm through the drilled hole and attach it to the damper as shown in FIG 32. When the damper is in the closed position, it is common that the bend on the damper arm is in a horizontal position.

Attention! Be careful that the set screw in FIG 32 is fastened securely! Follow the remaining steps up to FIG 34. Now the steel chimney or the flue pipe can be connected according to the instructions of the supplier.

Rear or Lateral Connection

FIG 35-40

An appropriate flue must be obtained by rear or lateral connection. The damper that is to be installed in the flue (FIG 54-60) is designed for flues with an outside diameter of 155 mm with a wall thickness of 2 mm. These measurements may vary from manufacturer to manufacturer, but most manufacturers adhere to these measurements.

Depending on the placement of the chimney, a hole must be cut in the PowerStone element as shown in FIG 35. Place the bushings (A-B) and pull the flue pipe from the inside. Remove the damper from the supplied flue pipe and mount it in the appropriate flue as shown in FIG 54-60. Note that it is easier to drill if you first use a 3-4 mm drill. The included sticker is placed on the flue. If the pipe has the correct dimensions, as described above, then will the drilling at the two marked areas ensure that the damper is mounted in the centre of the tube.

The position of the damper in the flue pipe can be adapted to aesthetic and practical optimum. The length of the damper arm can also be adapted as shown in FIG 59. The flue pipe should protrude about 2 cm from the inner core. The gap between the inner core and the flue pipe is sealed from within with refractory gasket and stove cement (not included). The gap between the surround and the flue does not technically need to be sealed, but if for cosmetic reasons it is desirable to seal it off, we recommend using a suitable decorative ring.

Complete the assembly as shown in FIG 41-52.

FIG 41-52 Assembly of the Combustion Chamber:

Proper installation of the Thermotte® plates and the cast iron back plate, as shown in FIG 44, is important for the function of the combustion chamber. It is important that all pre-assembled gaskets and the gasket shown in FIG 41 provide a good seal between the elements. Assemble the items in the order shown in the illustrations.

FIG 52-53 Installation of the Door

To meet government requirements in certain European countries, all doors are self-closing. If this is not a requirement in your area, this feature can be disabled by following the procedure in FIG 53.

Fig 1

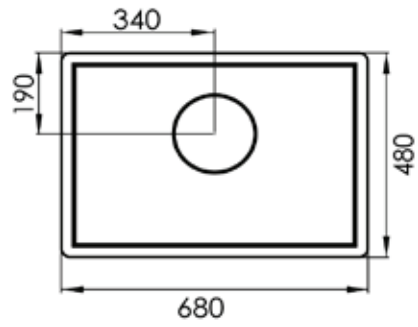
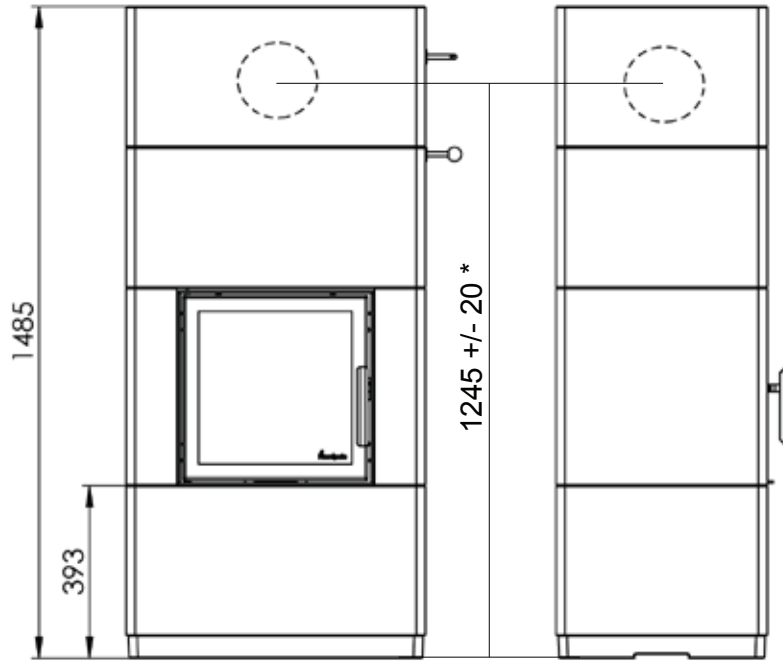

Salzburg high/
hoch

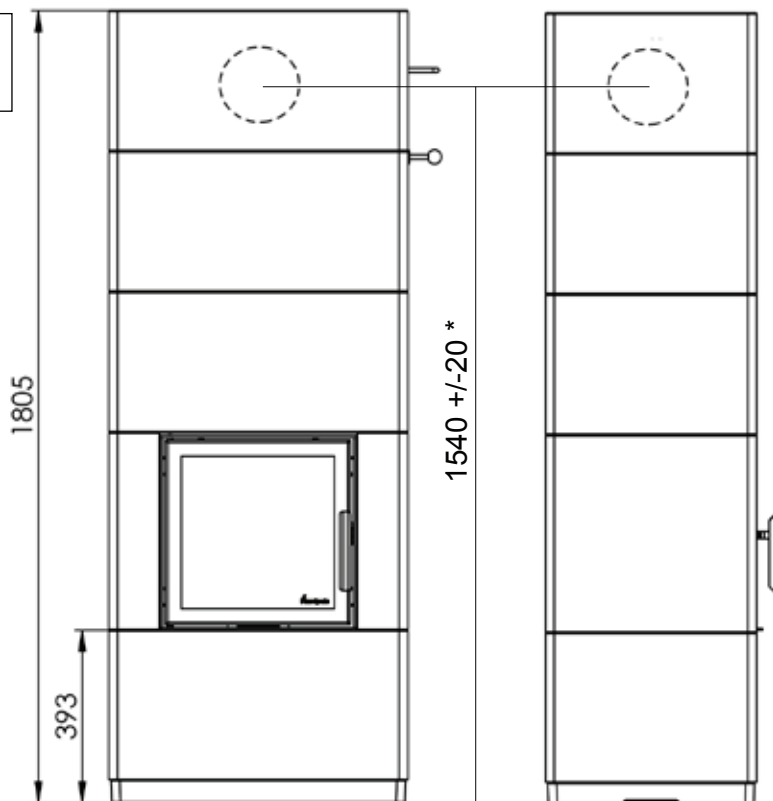

Salzburg Air/ Zuluft

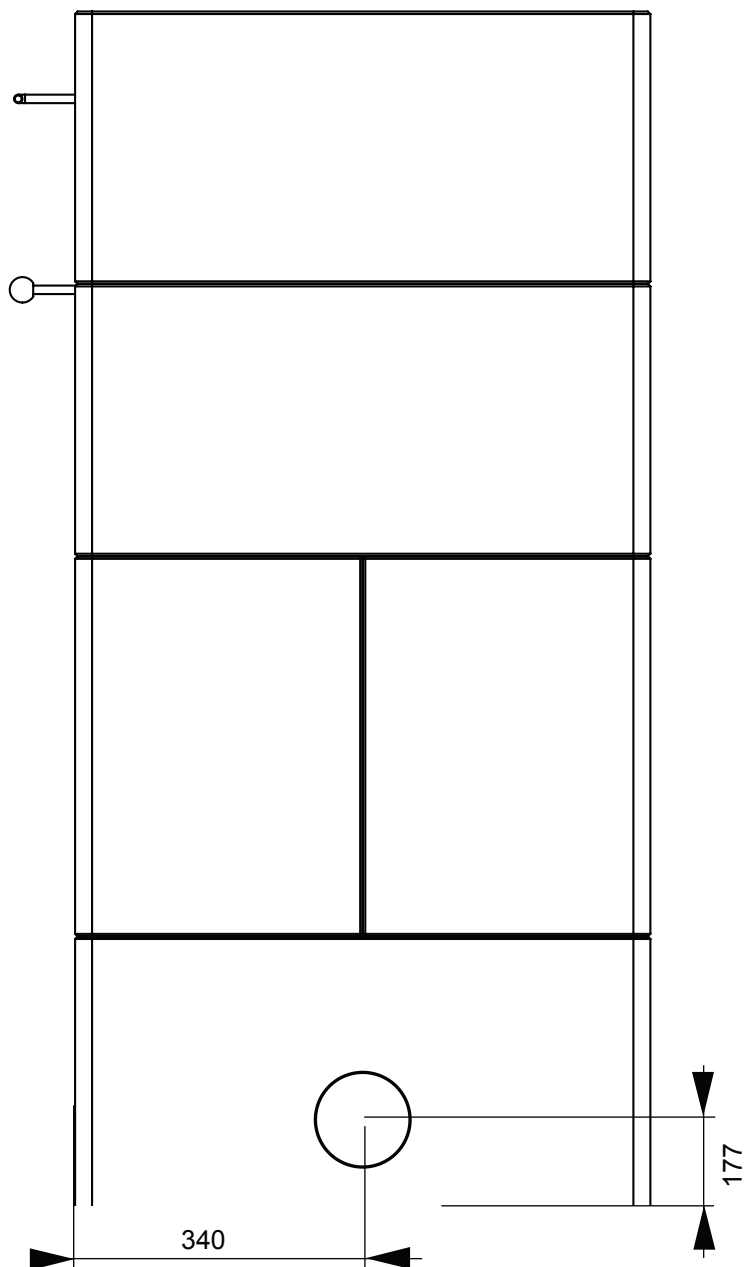
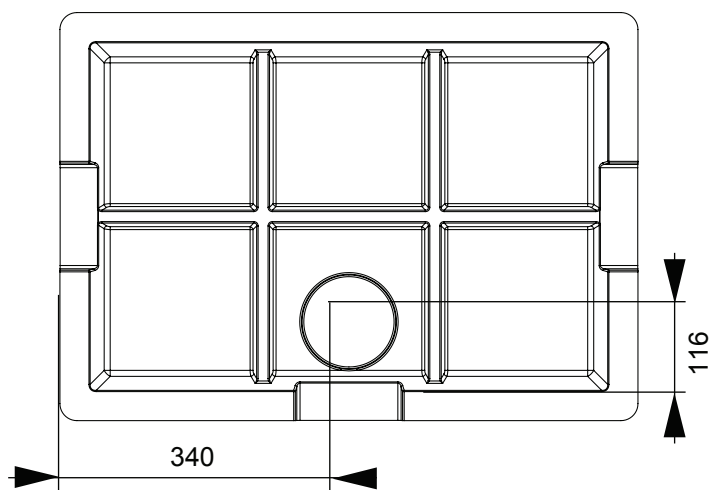



FIG 2

-  = Brannmur/Brandmur/Palomuri//Firewall/Mur parefeu/Hitzenschutzwand
-  = Brennbar materiale/Brændbart materiale/ Brännbart material/ Tulenarka materiaali/Combustible material
Matières combustibles/Brennbarem Material

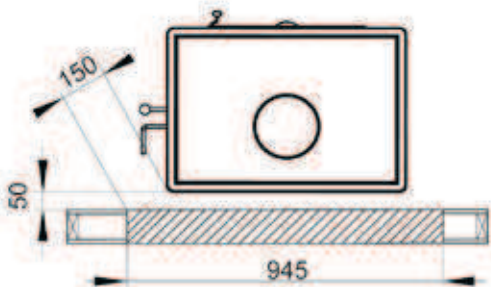
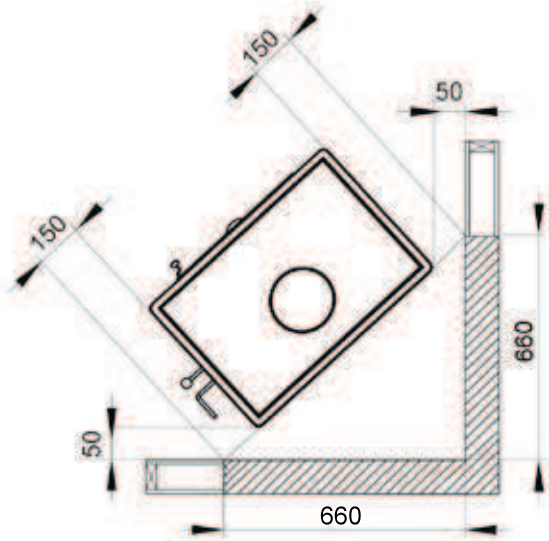
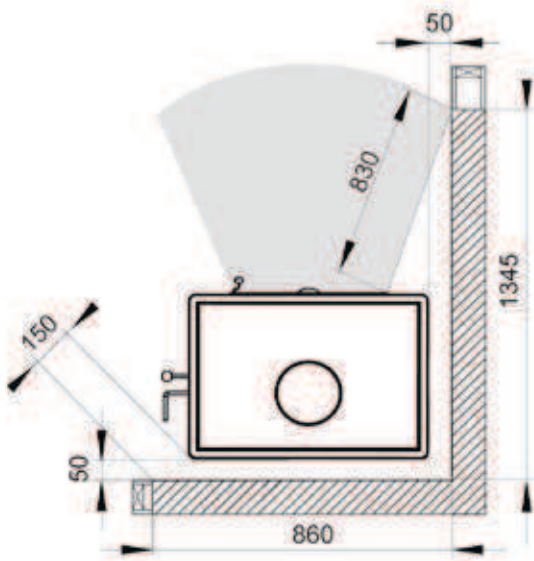
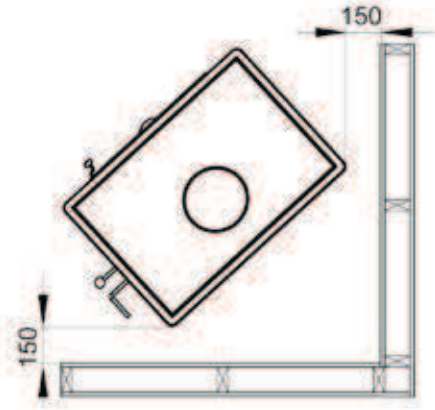
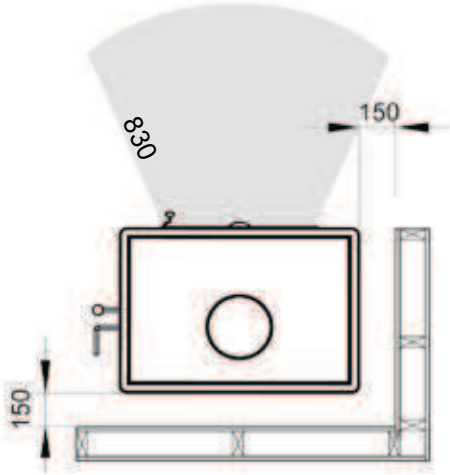
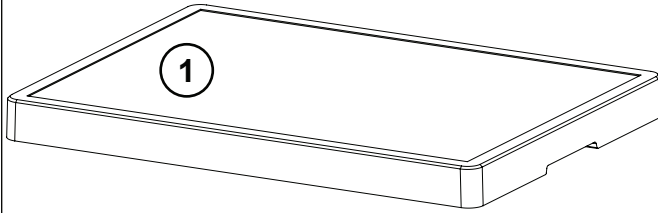
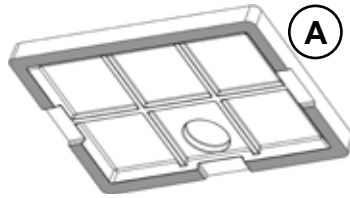
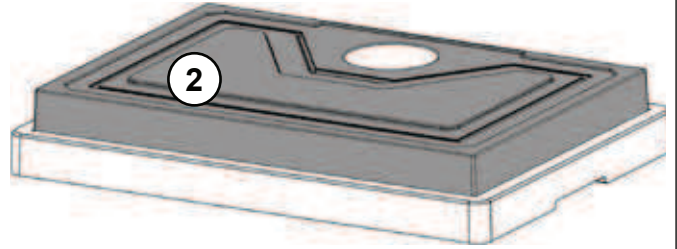

FIG 3



CO-SAL00-001

FIG 4



PN-SAL00-P01

FIG 5

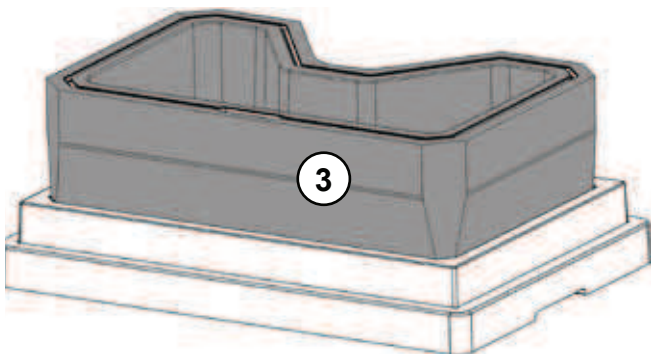

PN-SAL00-P02

FIG 6

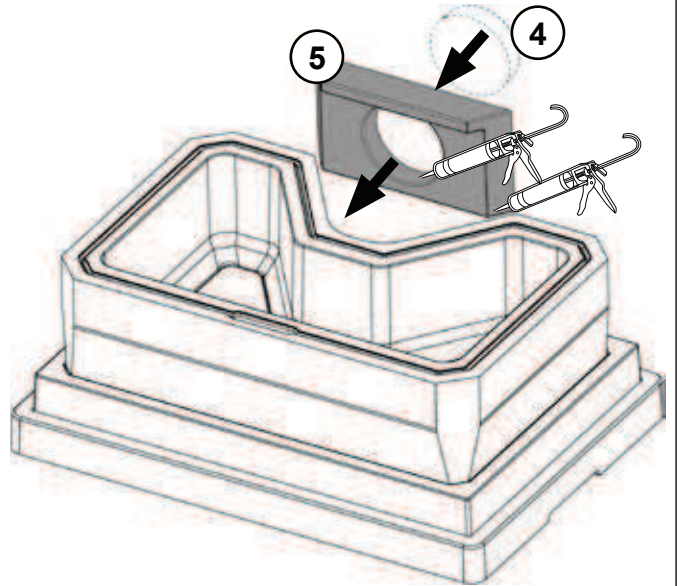

PN-SAL00-P04

PN-SAL00-P03

FIG 7

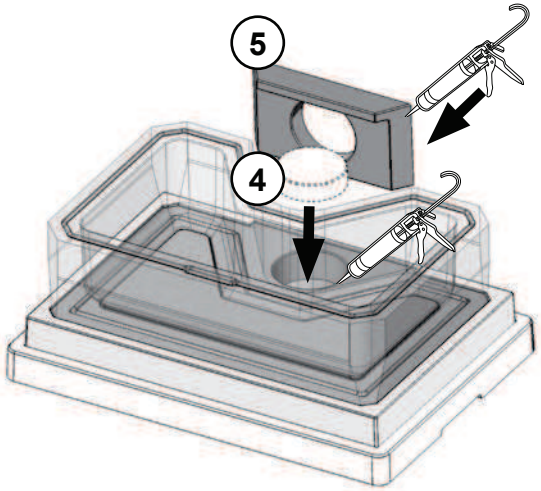

PN-SAL00-P04
PN-SAL00-P03

FIG 8

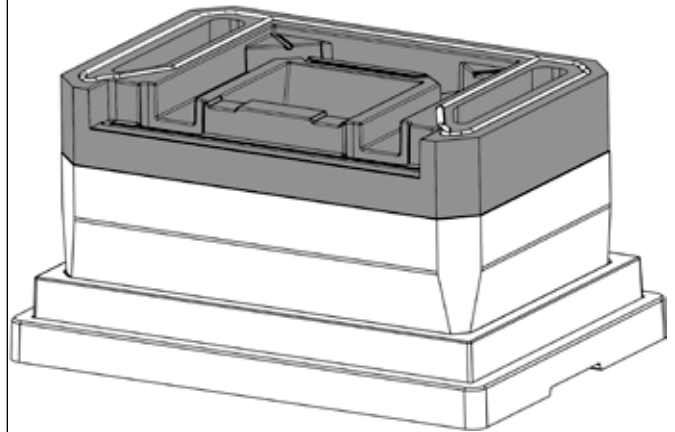

PN-SAL00-P05

FIG 9

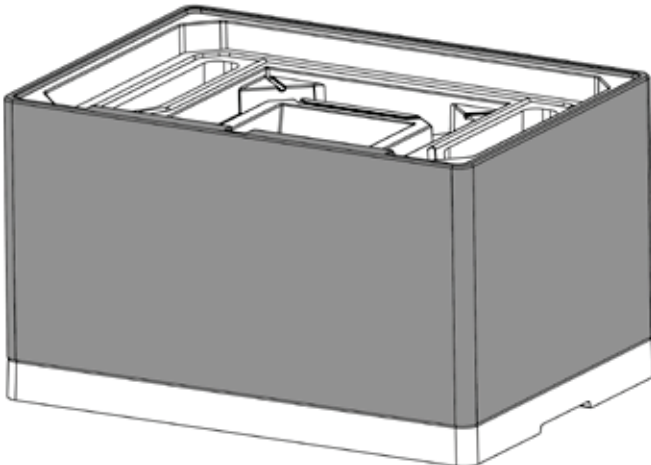
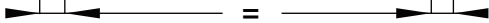
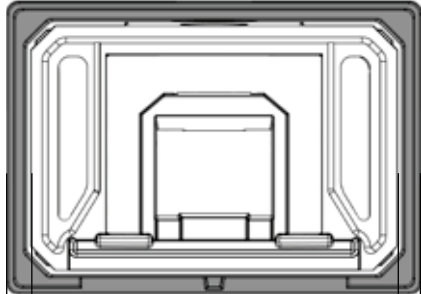

CO-SAL00-002

FIG 10

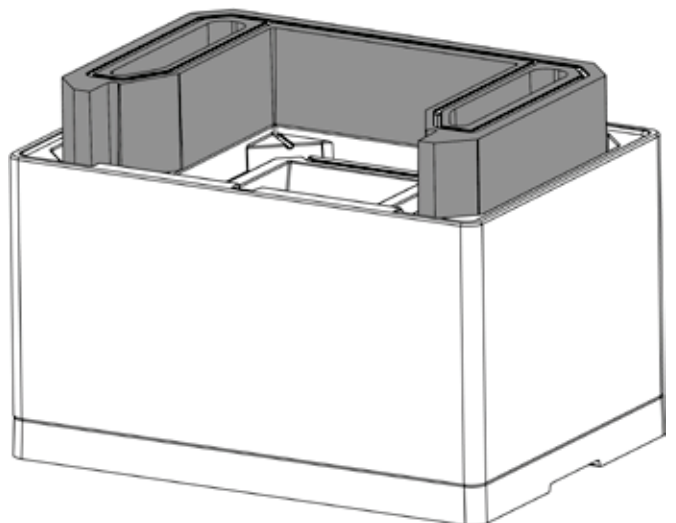

PN-SAL00-P06

FIG 11

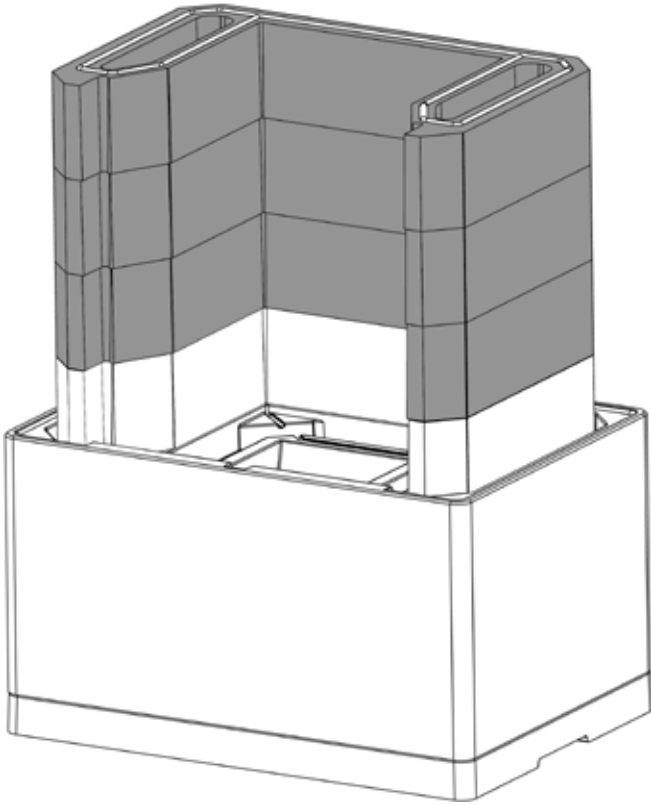

PN-SAL00-P06

FIG 12

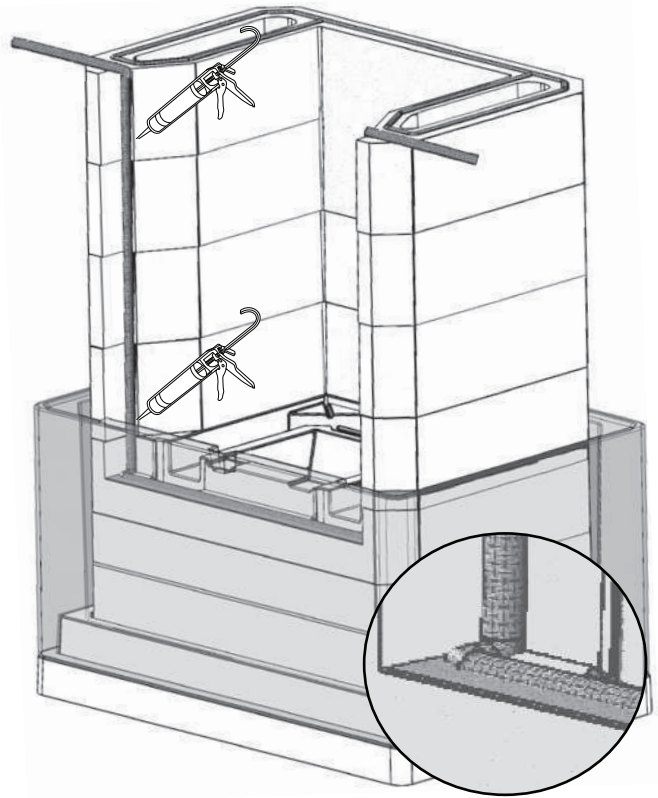

04-26412-000

FIG 13

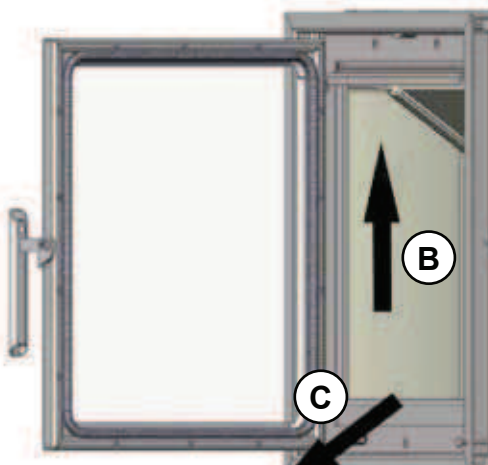
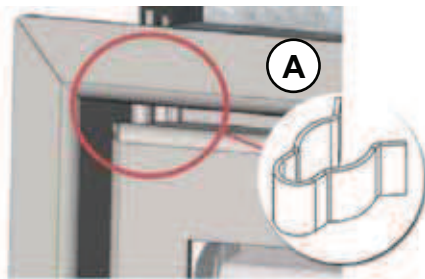
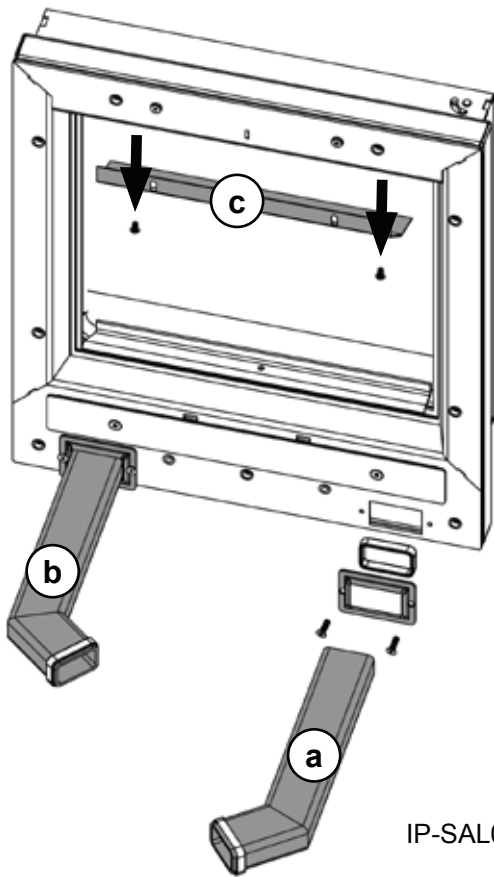
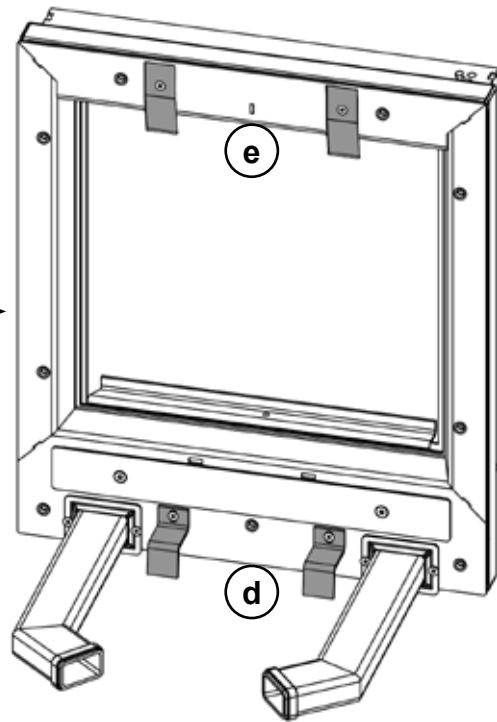
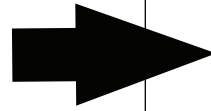

FIG 14



IP-SAL00-030



22-SAL00-060

22-SAL00-220

FIG 14b

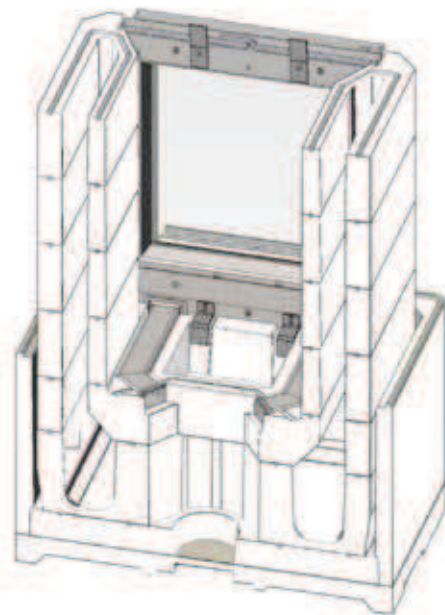
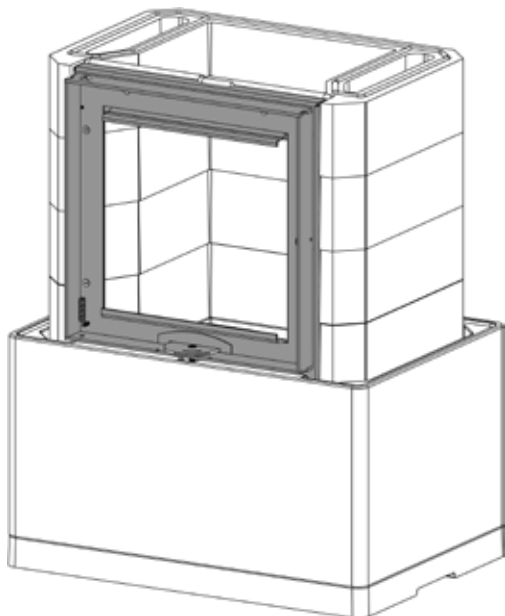

FIG 15

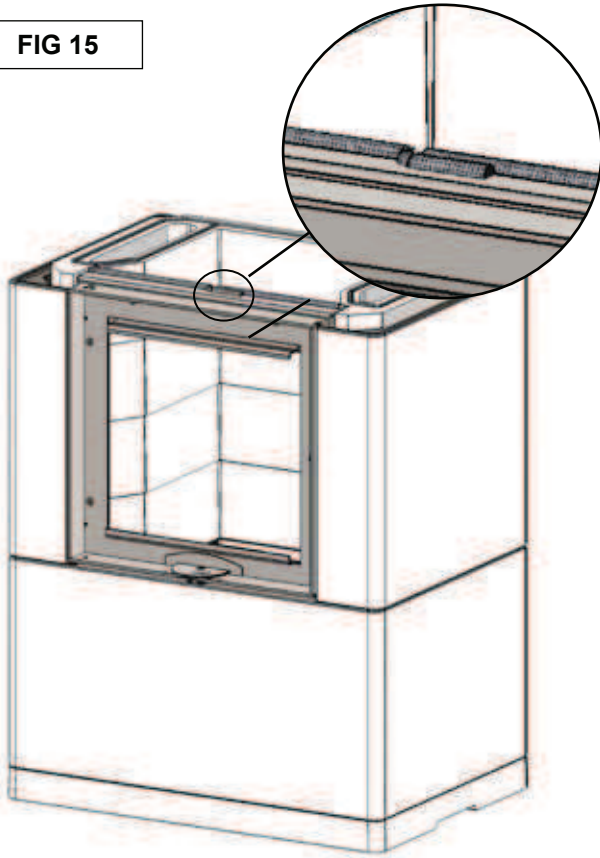
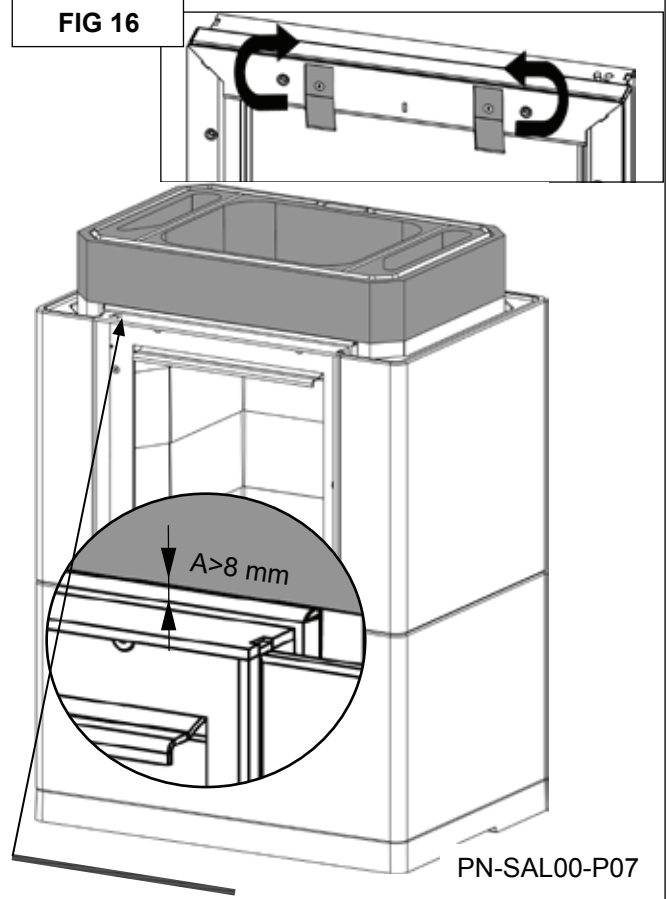
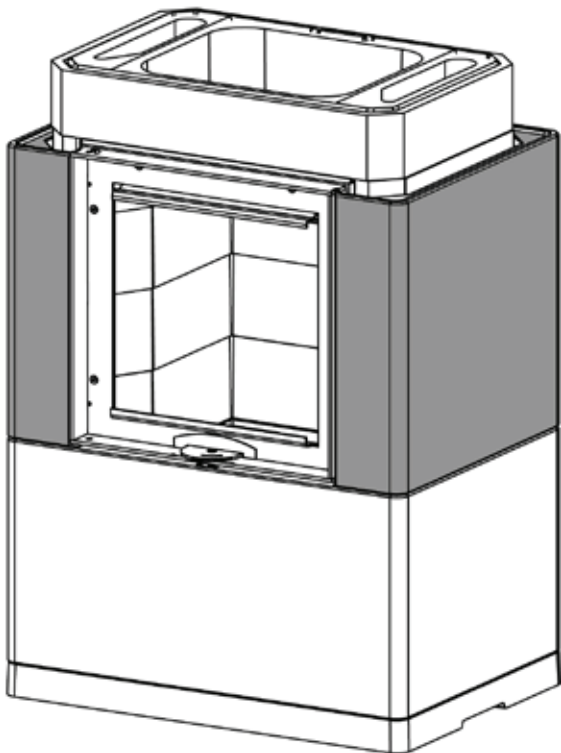

FIG 16



PN-SAL00-P07
04-26420-010

FIG 17



CO-SAL00-003
CO-SAL00-004

FIG 18

Salzburg Optional extension

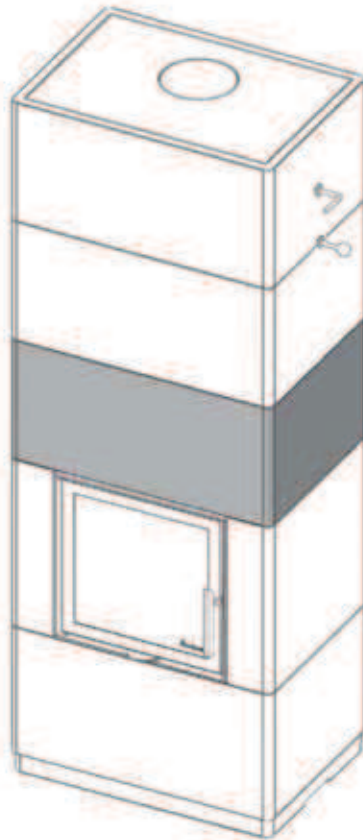
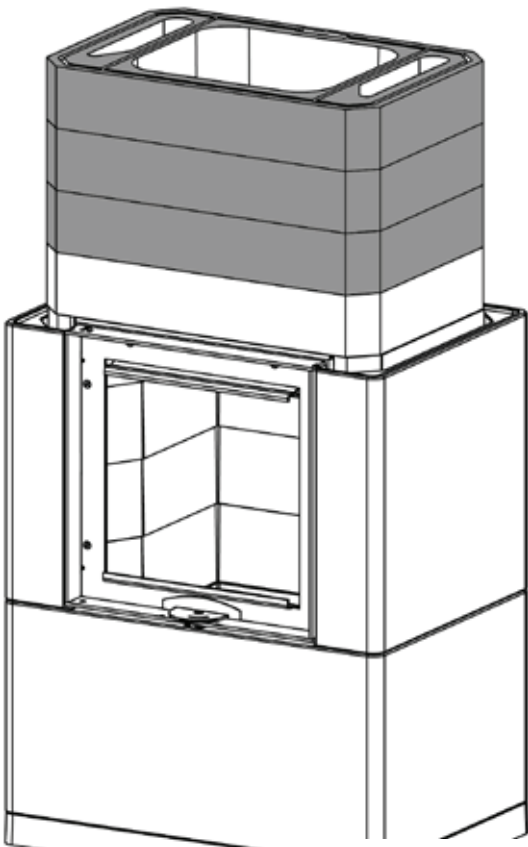
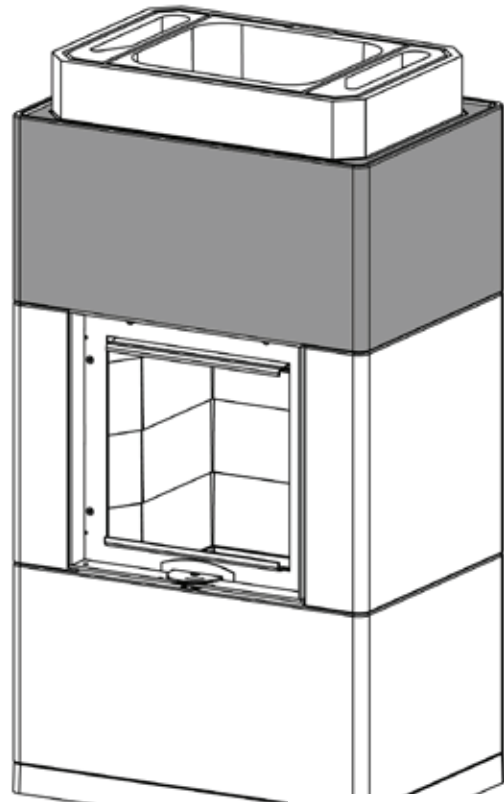

FIG 19



PN-SAL00-P07 (EXT 1-3)

FIG 20



CO-SAL00-005 (EXT 4)

FIG 21

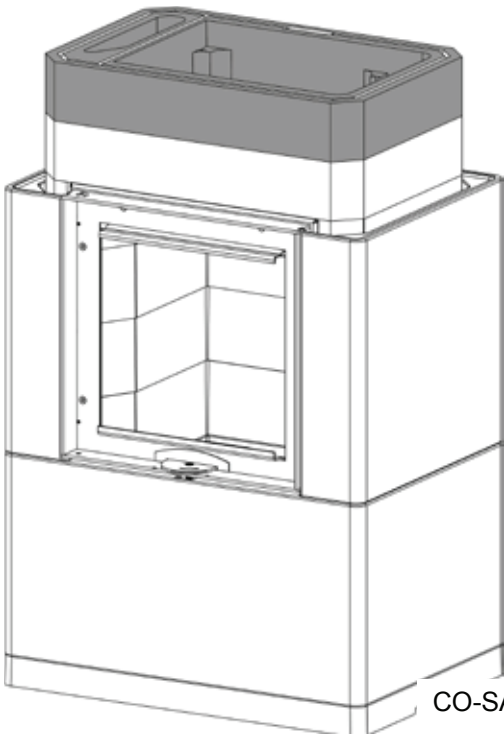
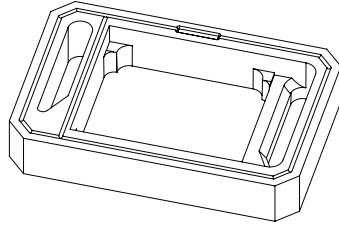

CO-SAL00-P08

FIG 22

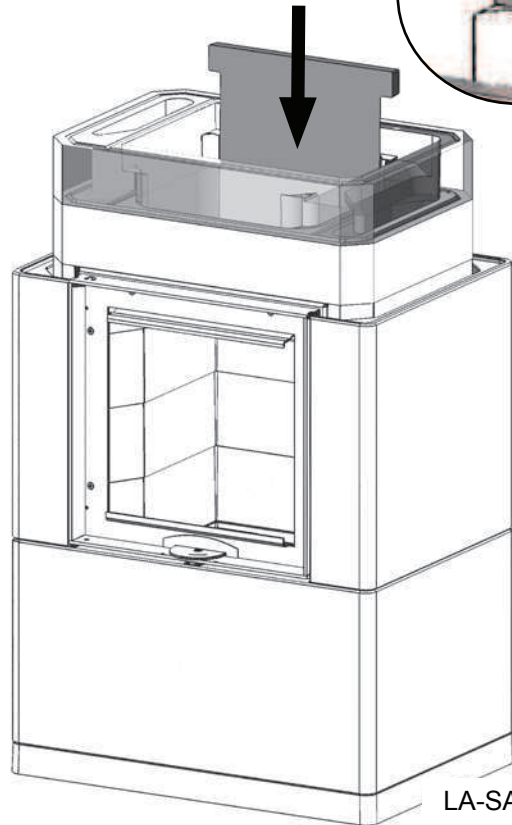

LA-SAL00-007

FIG 23

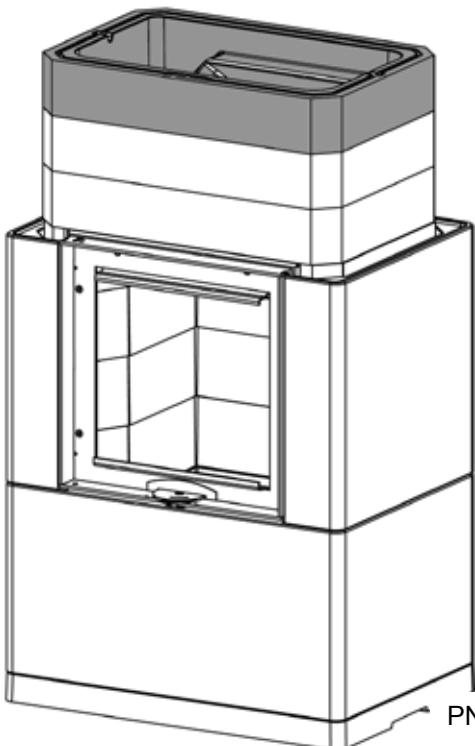
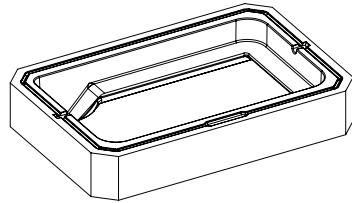

PN-SAL00-P09

FIG 24

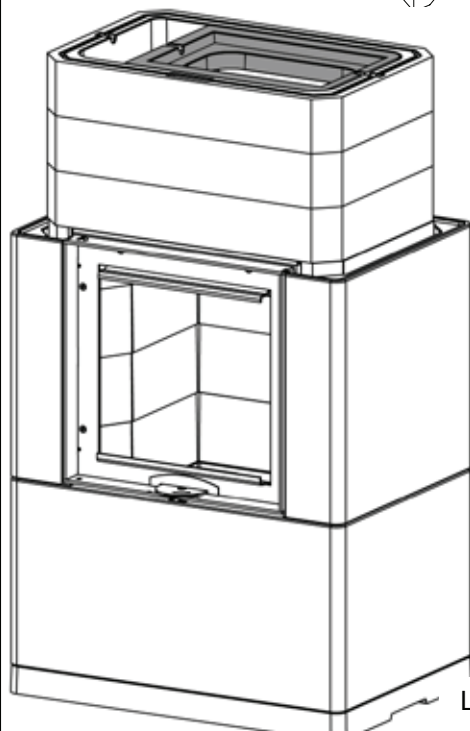
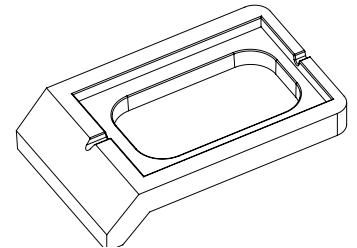

LA-SAL00-008

FIG 25

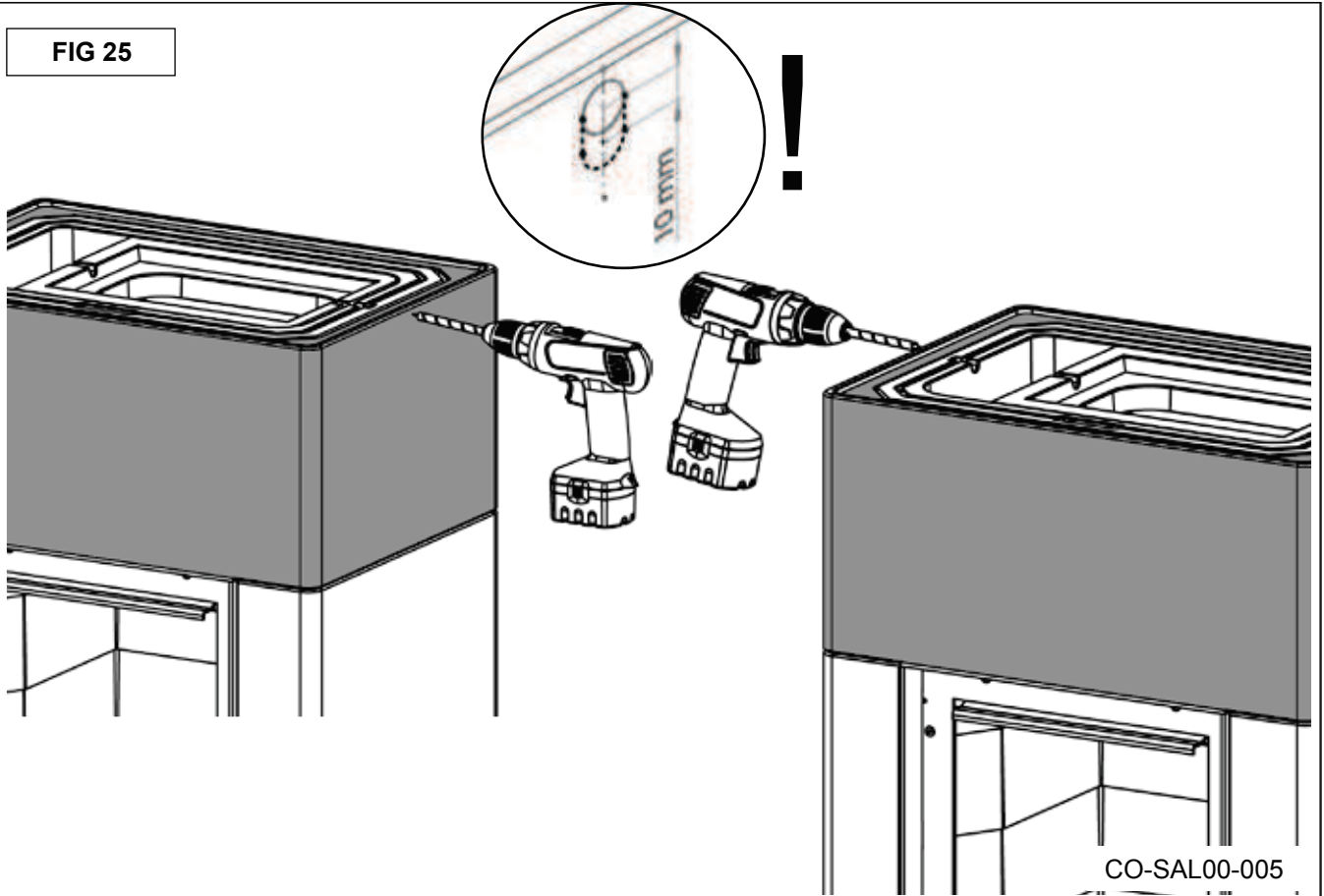
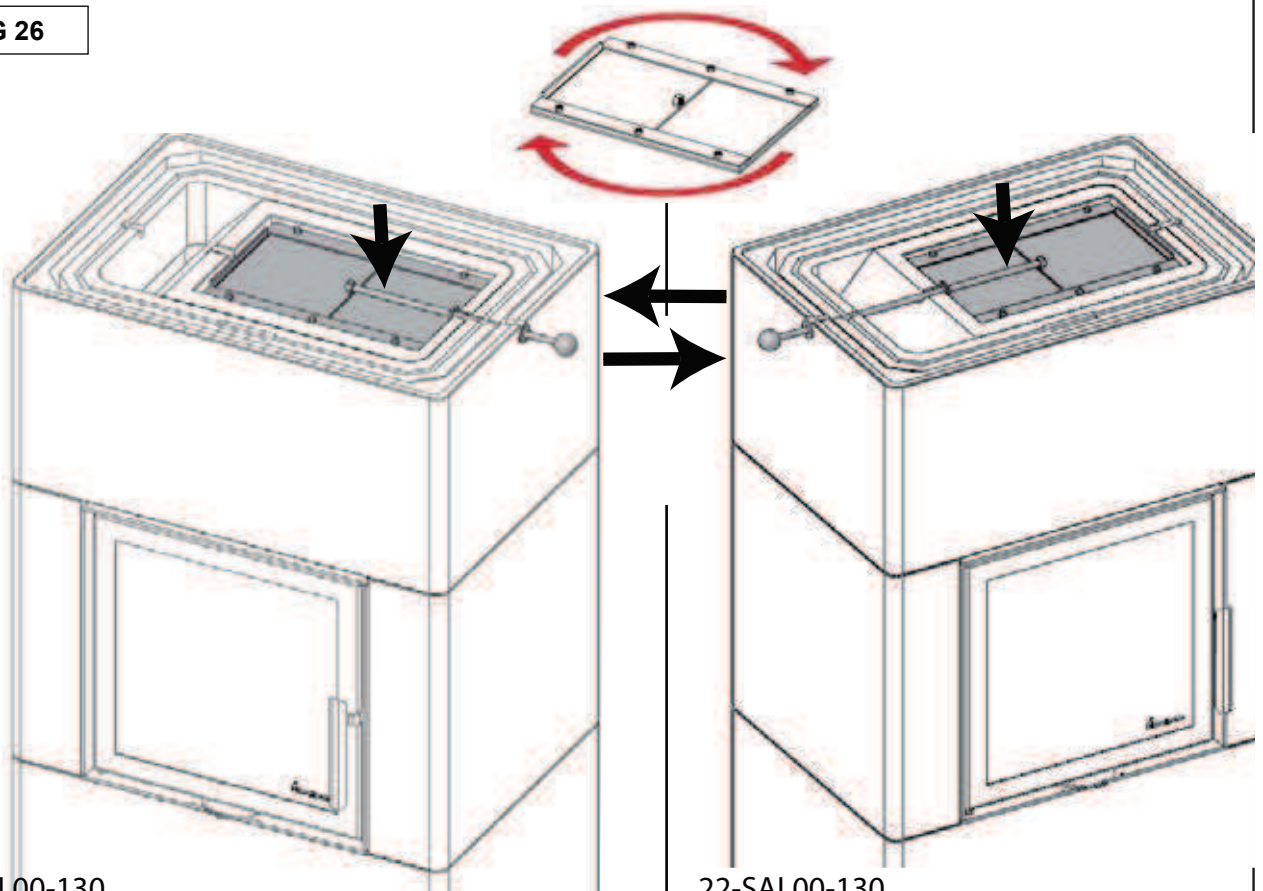

FIG 26



22-SAL00-130
22-SAL00-180 (l = 338mm)
22-SAL00-200
22-SAL00-210

22-SAL00-130
22-SAL00-190 (l = 459mm)
22-SAL00-200
22-SAL00-210

FIG 27

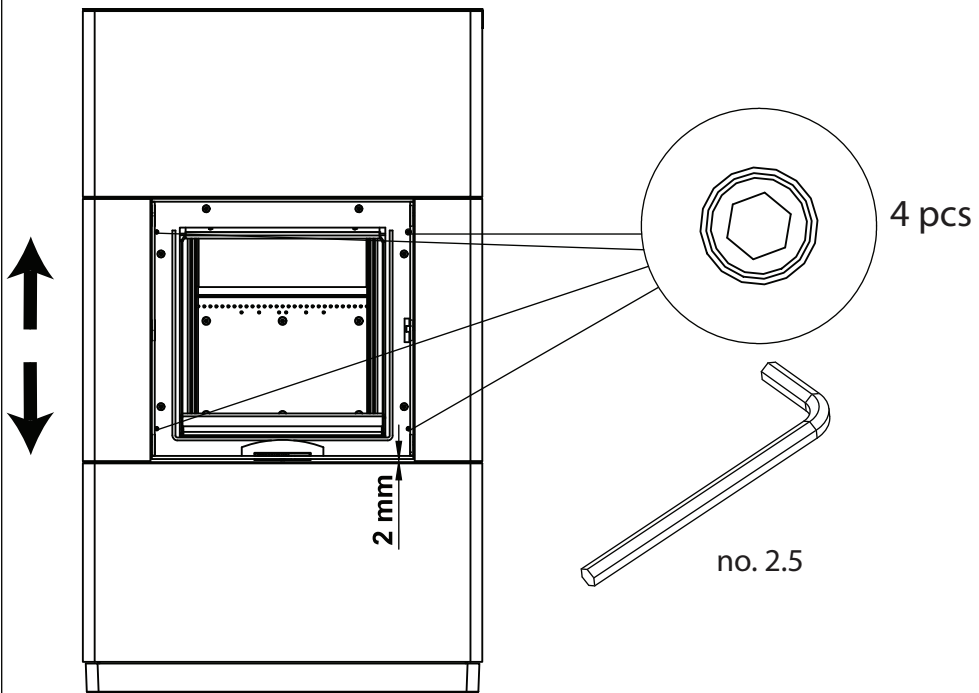

FIG 28

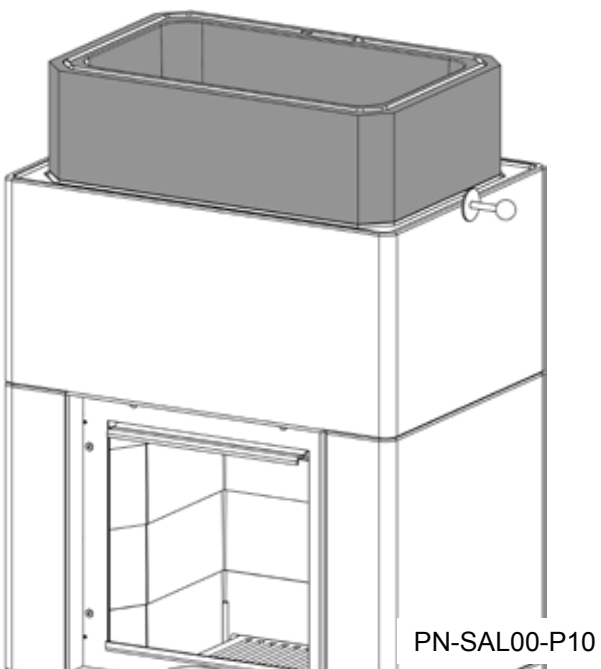

FIG 29

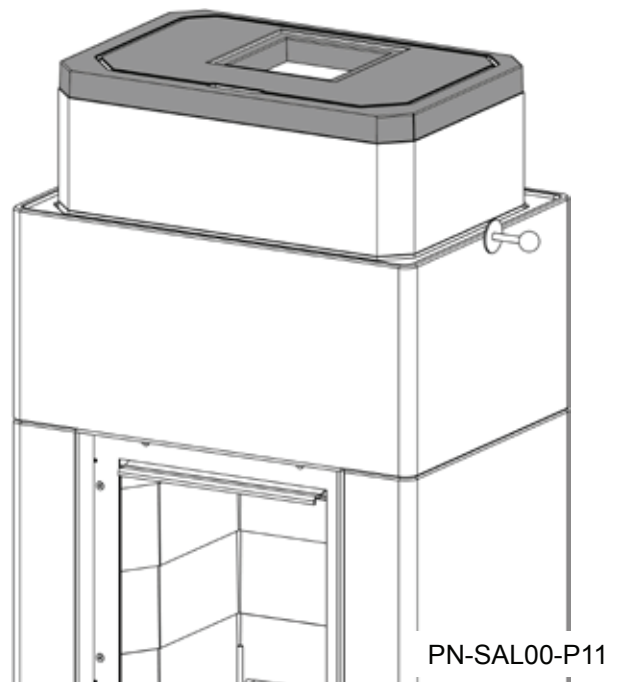
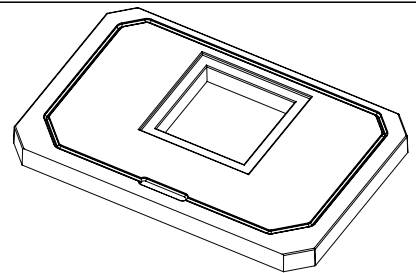
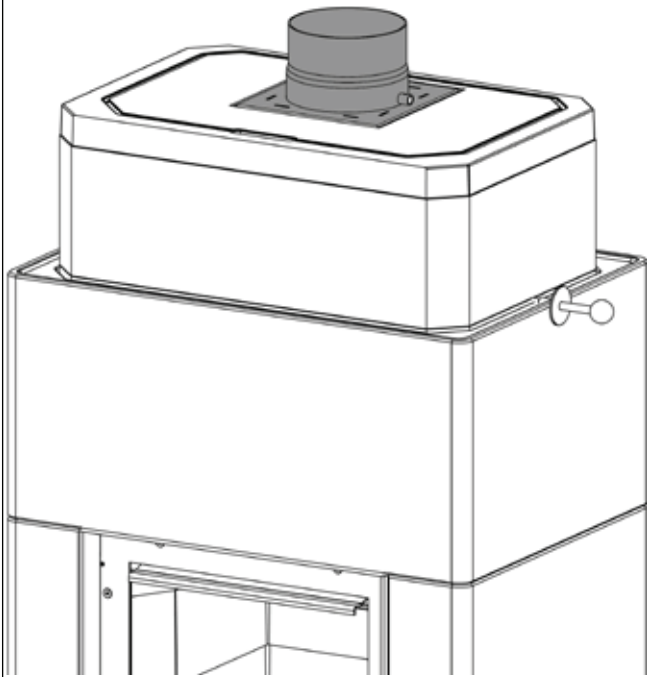
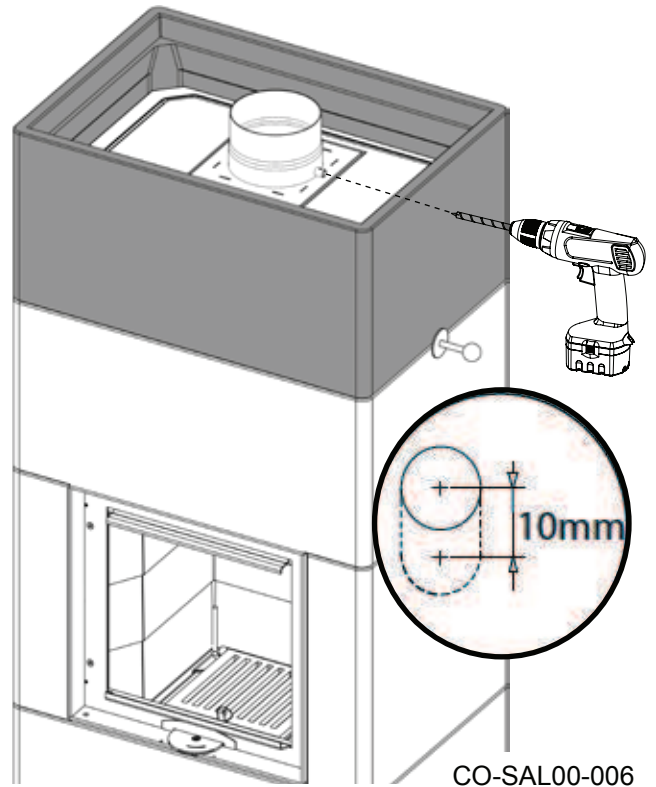

FIG 30



PN-SAL00-P10

FIG 31



CO-SAL00-006

FIG 32

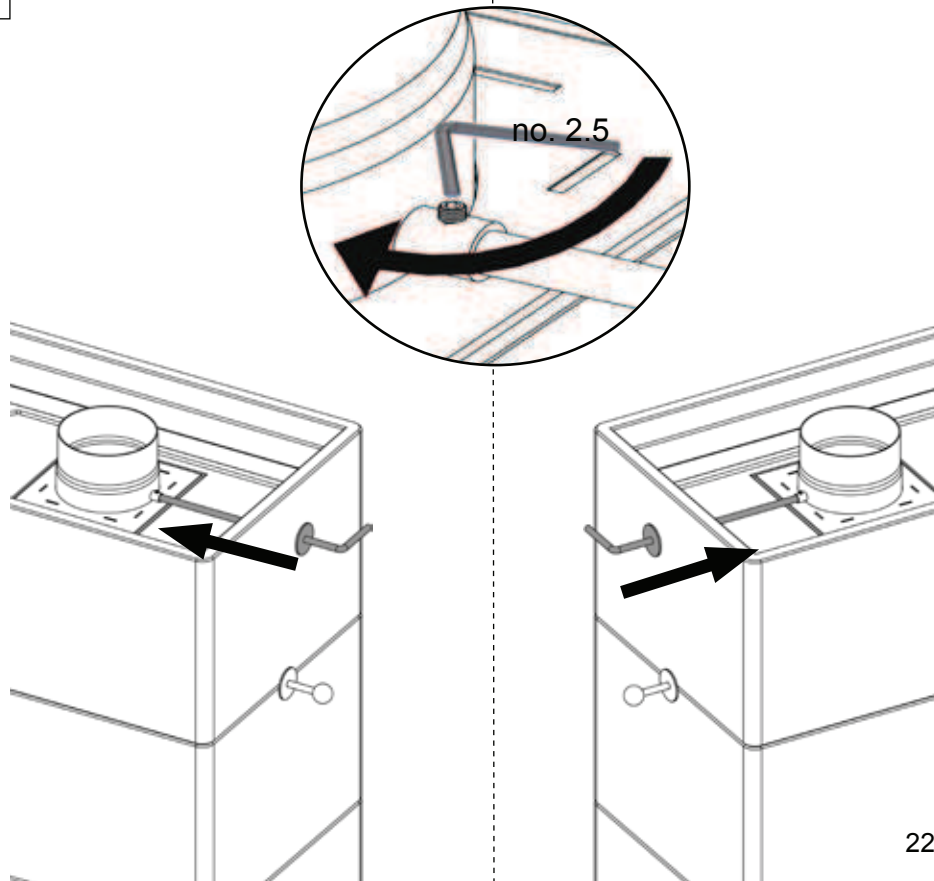

22-SAL00-230

22-SAL00-210

FIG 33

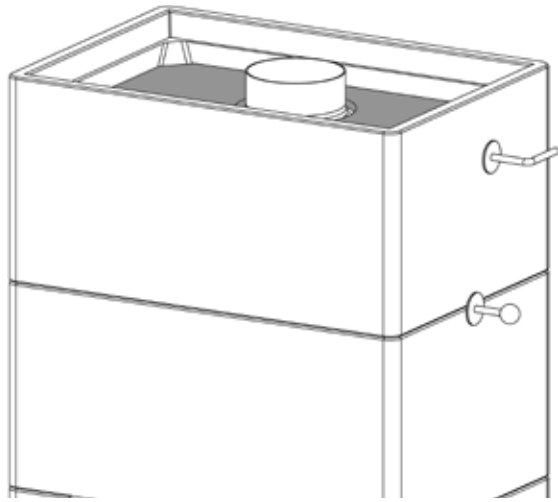
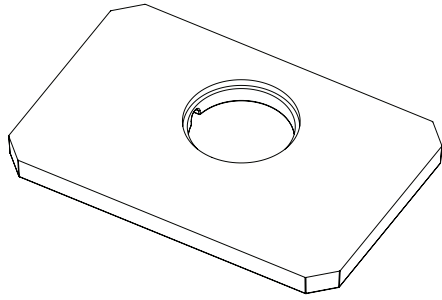

PN-SAL00-P13

FIG 34

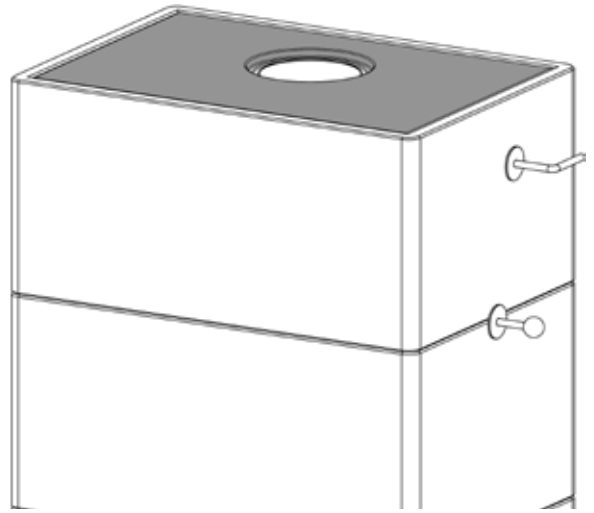

CO-SAL00-007

FIG 35

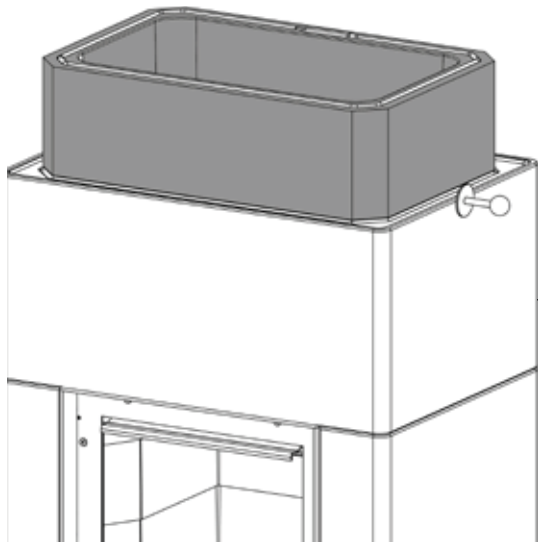

PN-SAL00-P10
PN-SAL00-P15(a/b)

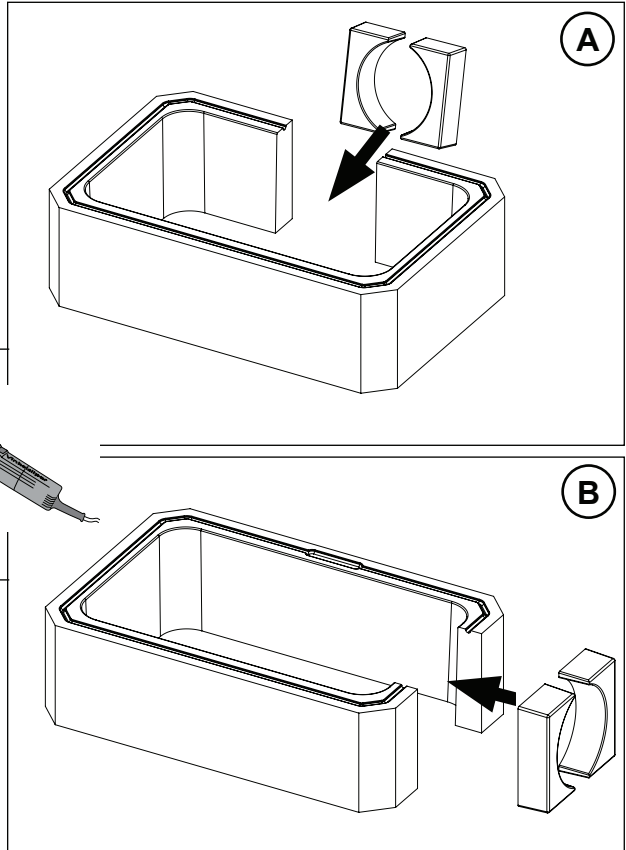

FIG 36

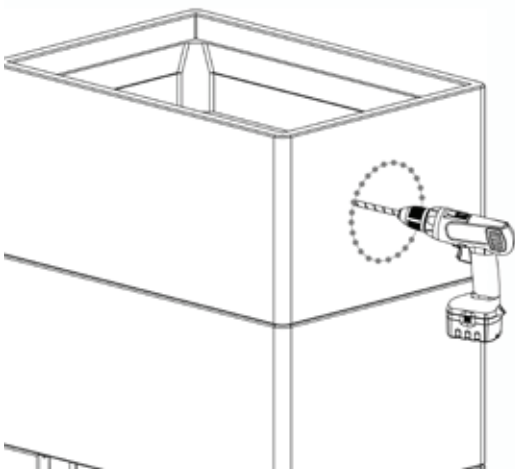

FIG 37

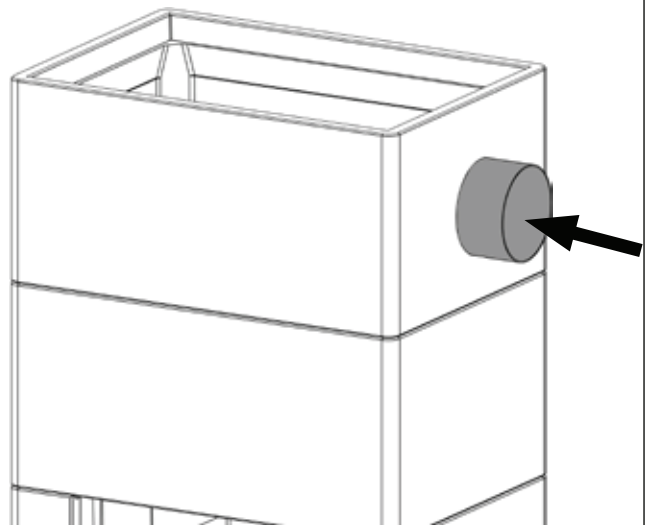
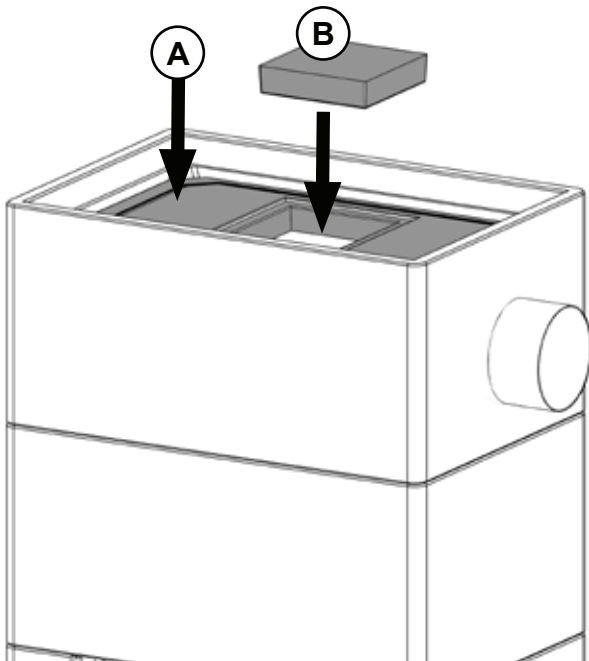
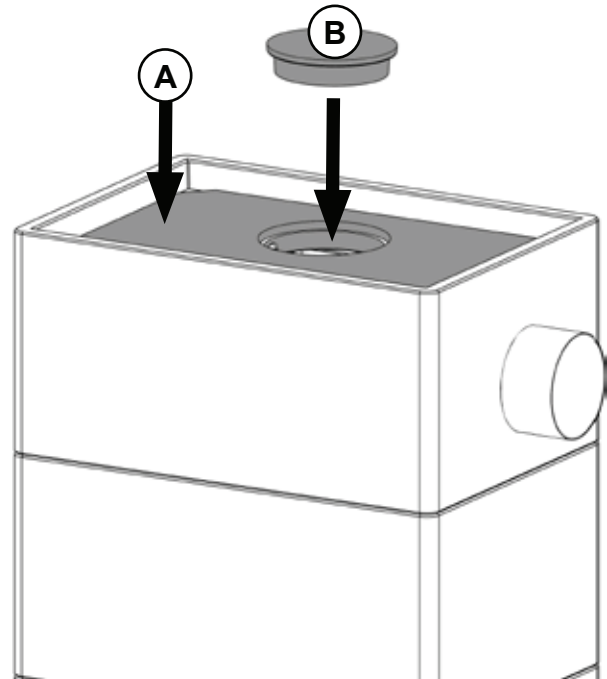

FIG 38



PN-SAL00-011(a)
PN-SAL00-012(b)

FIG 39



PN-SAL00-P13(a)
PN-SAL00-P14(b)

FIG 40

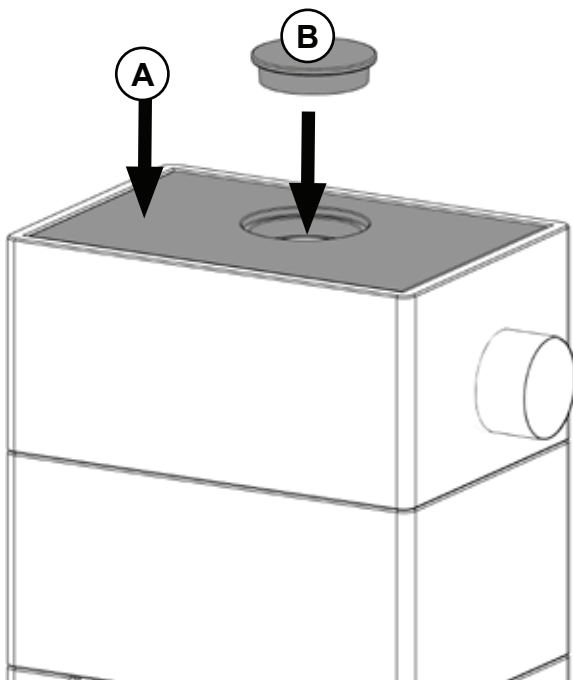

CO-SAL00-007(a)
CO-SAL00-008(b)

FIG 41

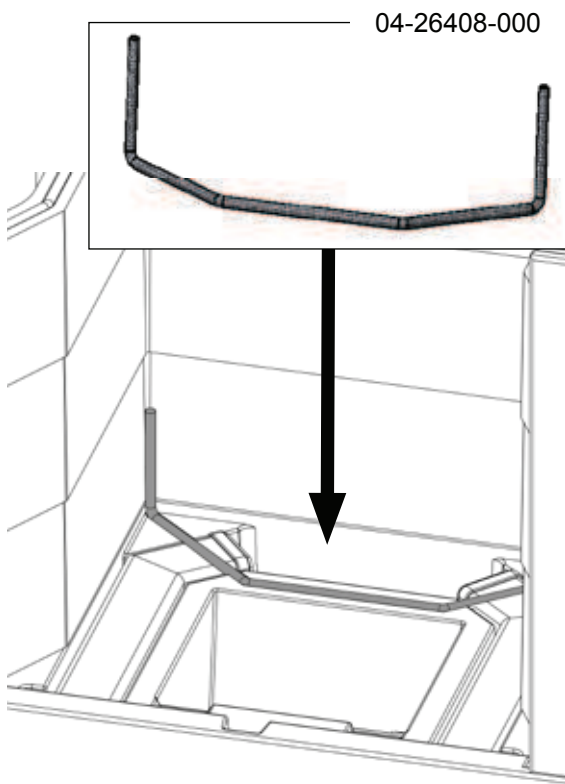

FIG 42

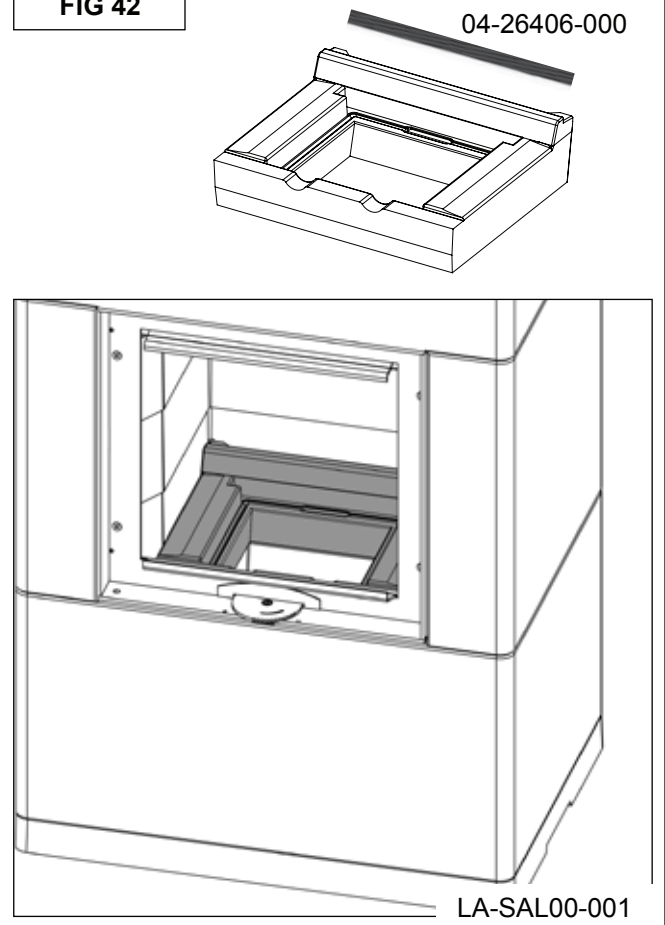

FIG 43

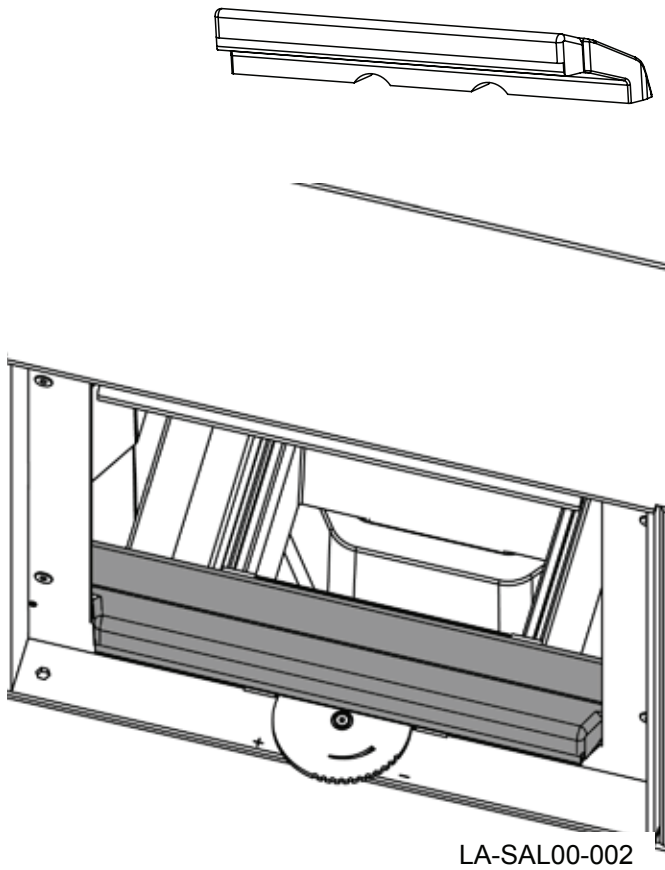

FIG 44

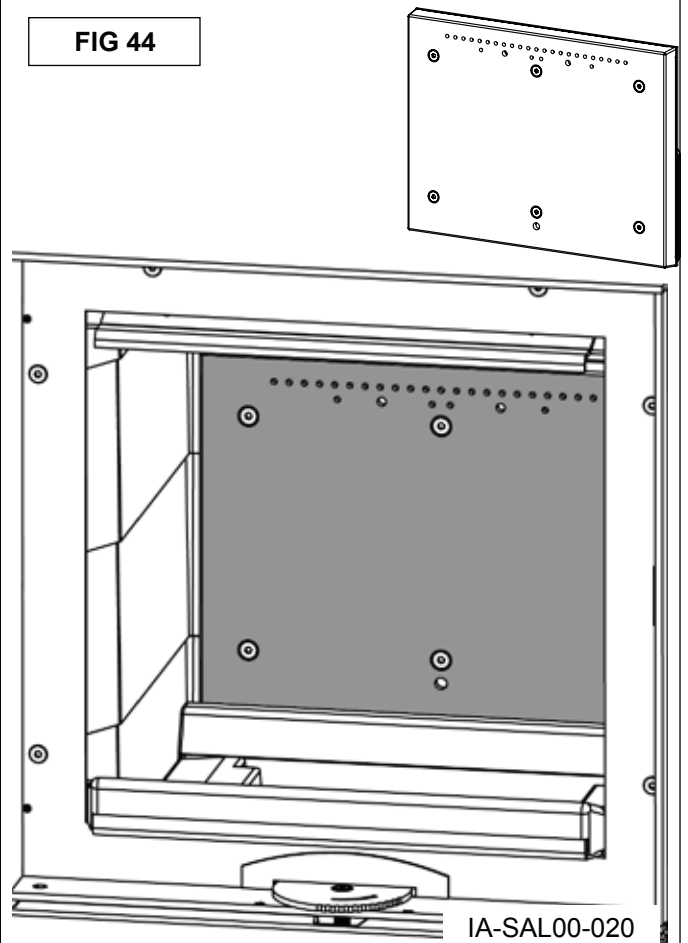
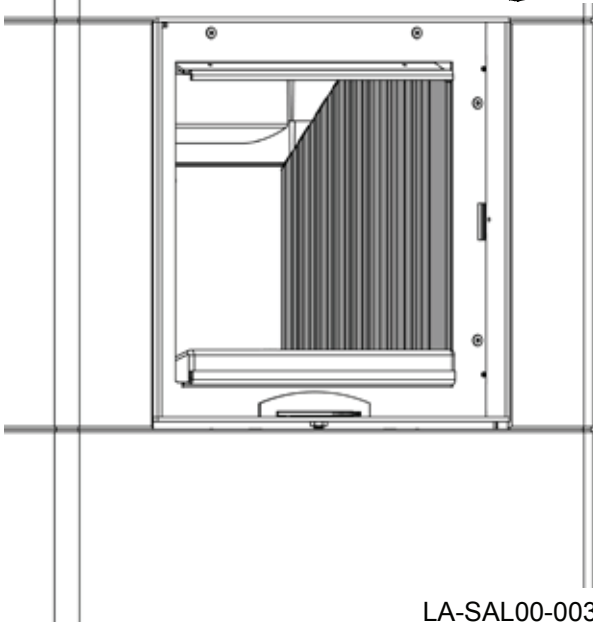
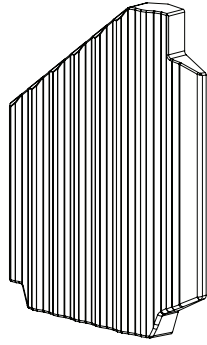
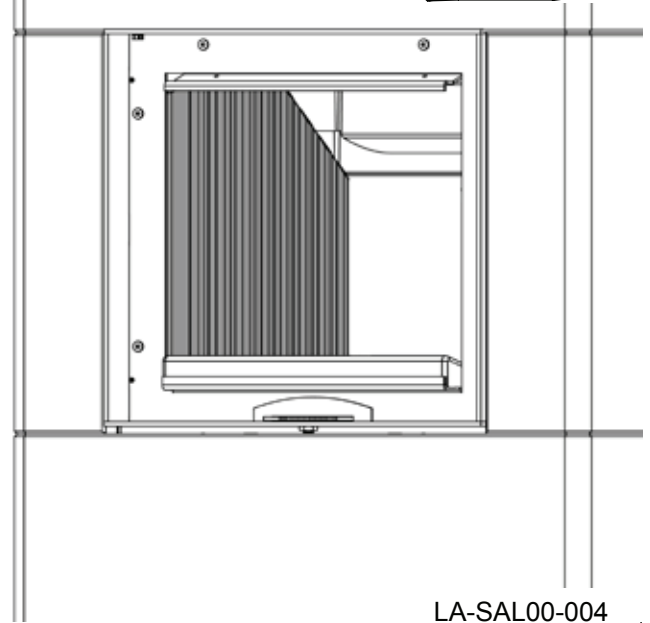
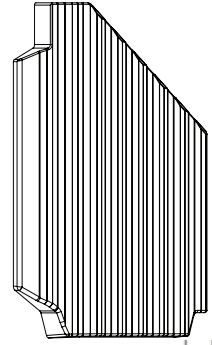

FIG 45



LA-SAL00-003

FIG 46



LA-SAL00-004

FIG 47

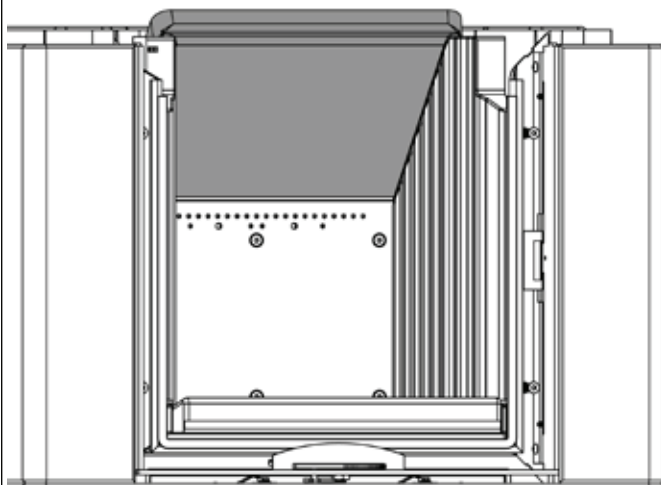
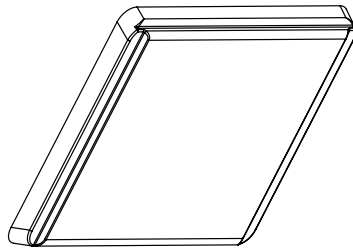

LA-SAL00-005

FIG 48

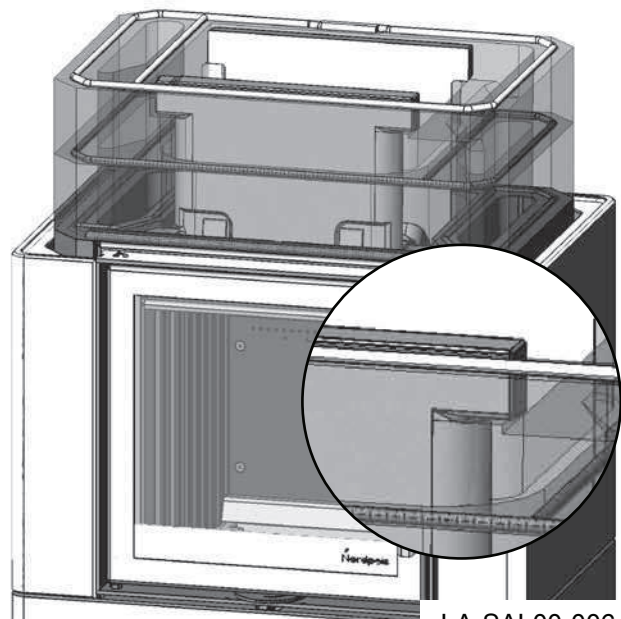
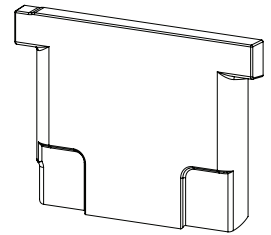

LA-SAL00-006

LA-SAL00-009 (only for Extension part)

FIG 49

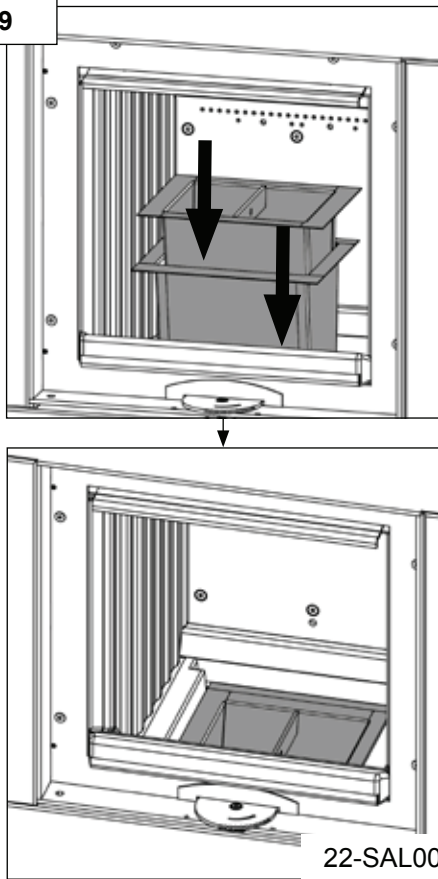

22-SAL00-150
22-SAL00-160

FIG 50

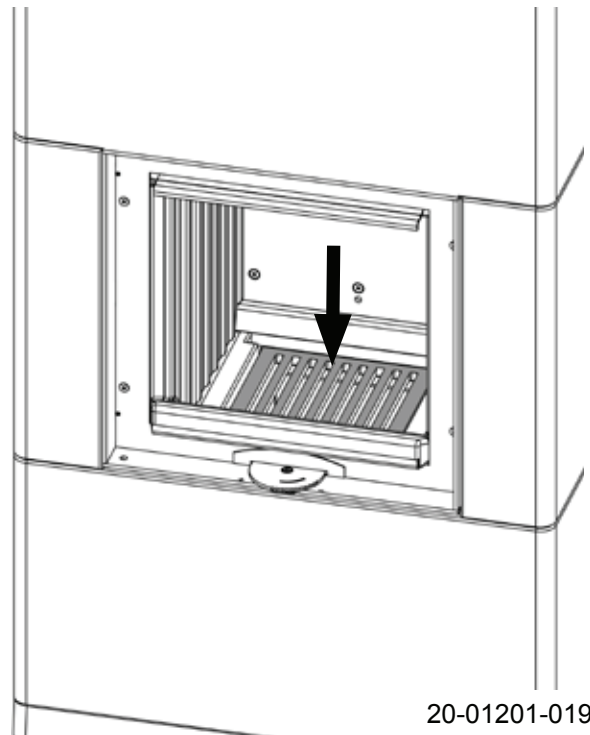

20-01201-019

FIG 51

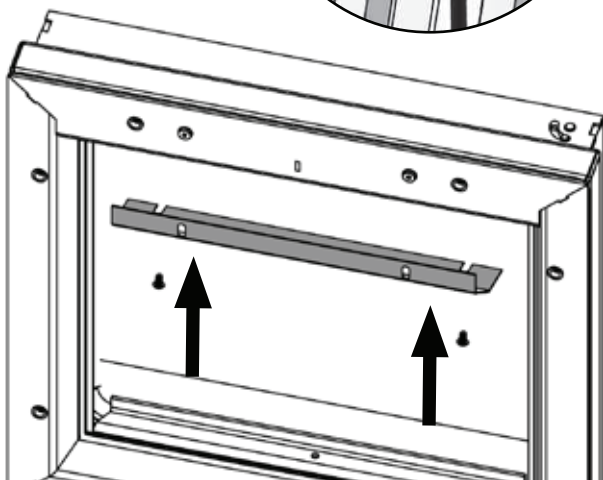
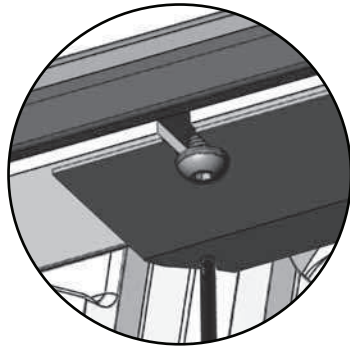

22-SAL00-270

FIG 52

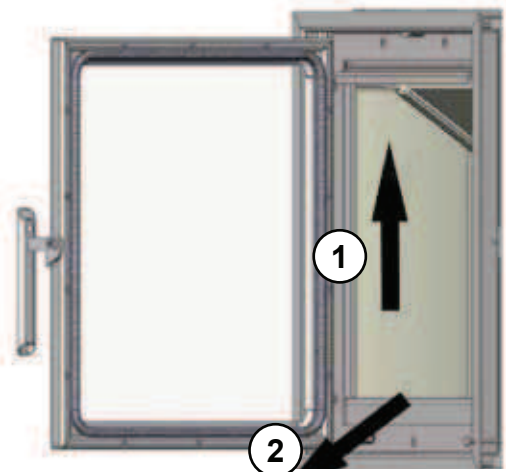

FIG 53

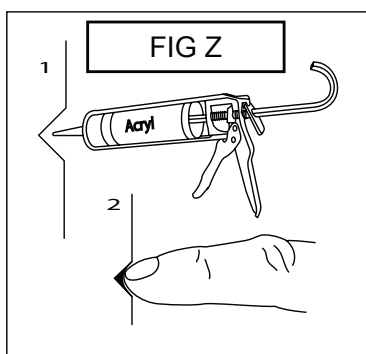
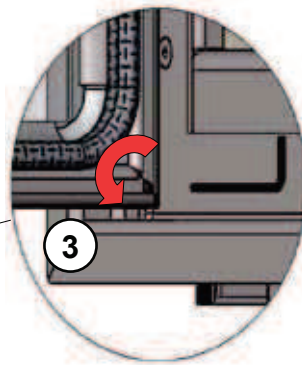
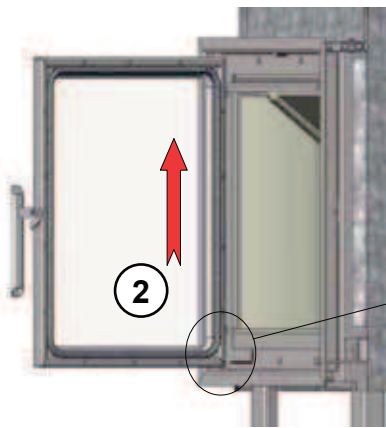
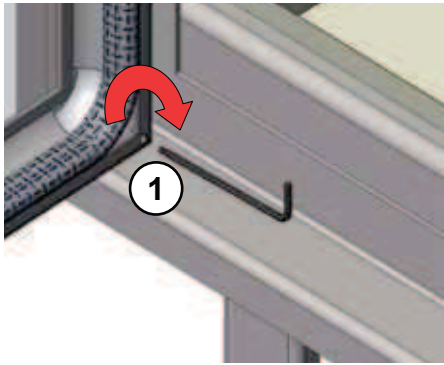
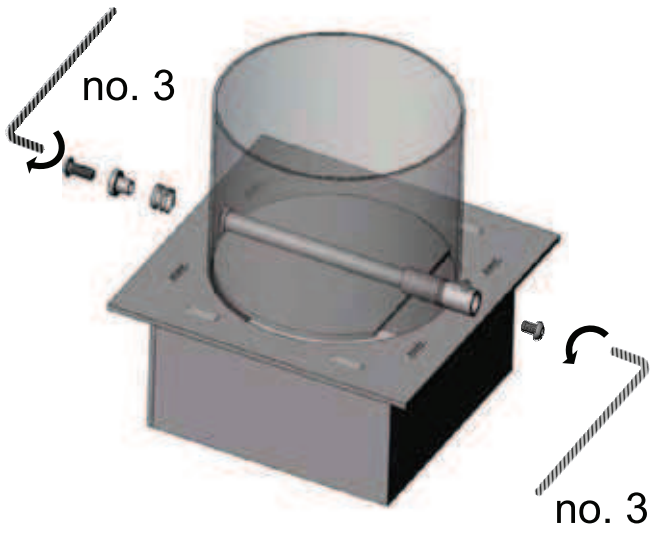
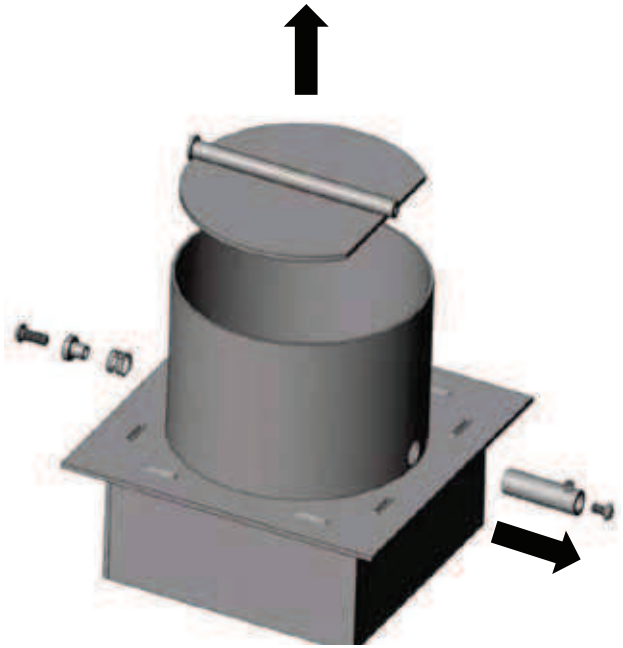

FIG 54



IP-SAL00-040

FIG 55



IP-SAL00-040

FIG 56

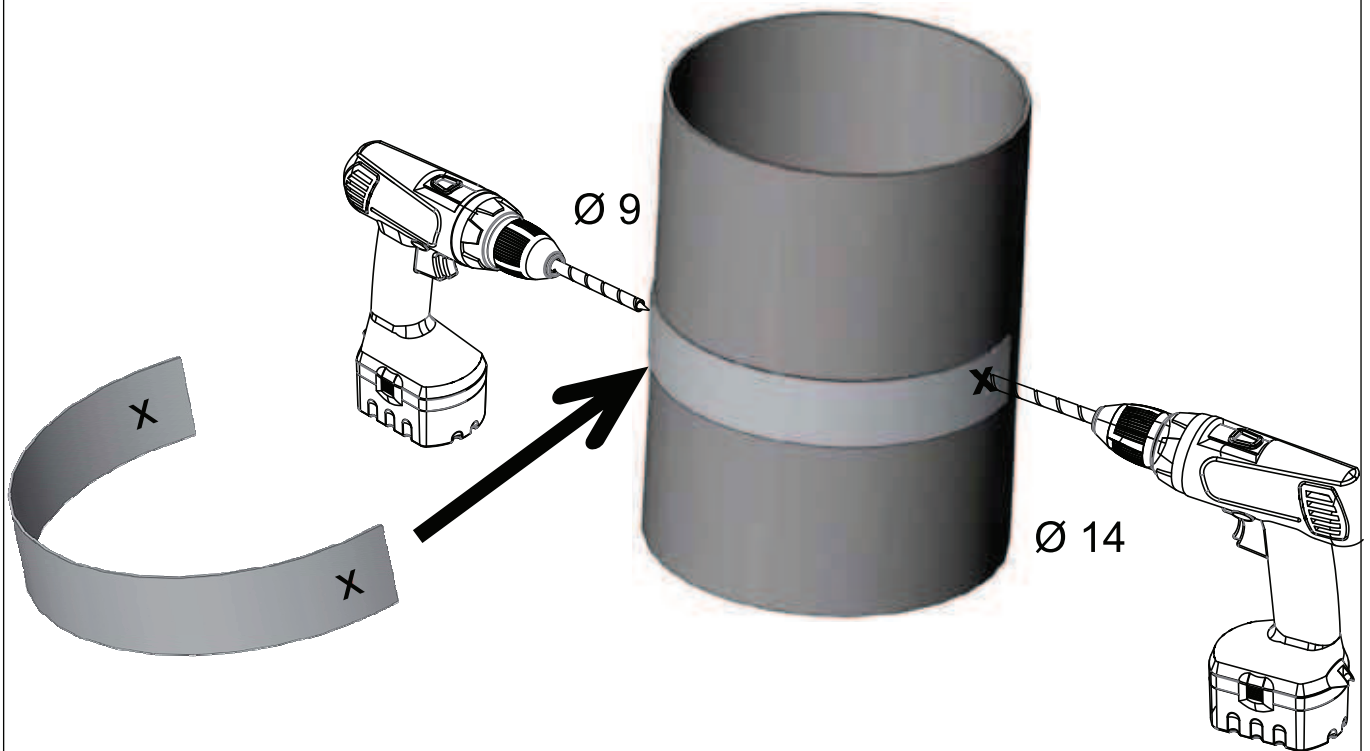

IP-SAL00-010

FIG 57

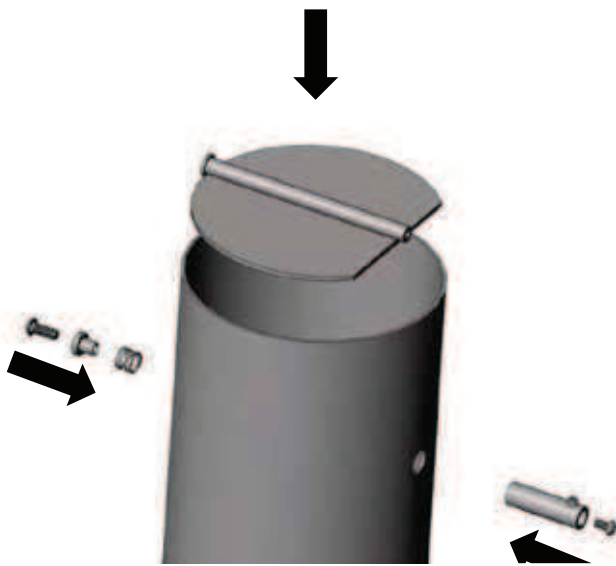

FIG 58

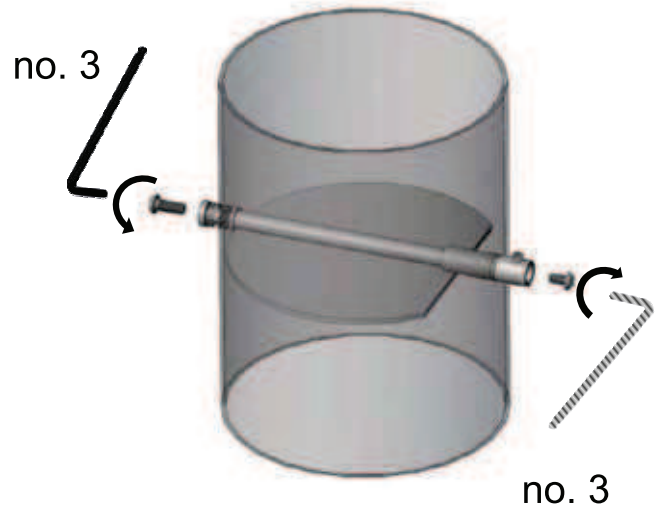

FIG 59

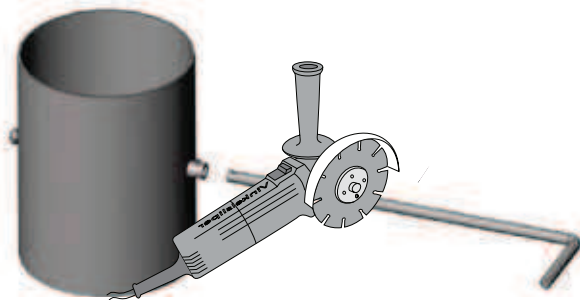
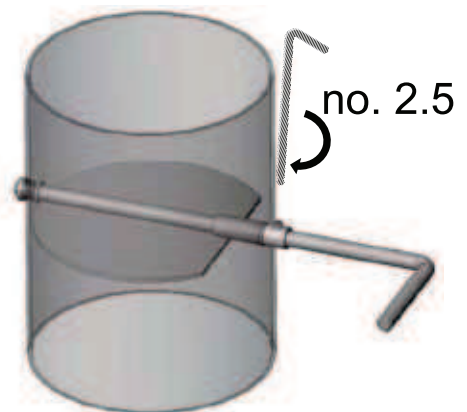

FIG 60



22-SAL00-230



Nordpeis AS, Gjellebekkstubben 9-11, N-3420 LIERSKOGEN, Norway
www.nordpeis.no